



INDUSTRIAL COMPUTER SOURCE®

Product Manual

MANUAL NO. 8701027

Revision L

SB486T2C/66

SB486TC/50

SB486TC/33

SB486SXTC/33

SB386SX/25



INDUSTRIAL COMPUTER SOURCE®

9950 Barnes Canyon Road, San Diego, CA 92121 (619) 677-0877 (FAX) 619-677-0895

INDUSTRIAL COMPUTER SOURCE EUROPE TEL (1) 69.18.74.30 FAX (1) 64.46.40.42
INDUSTRIAL COMPUTER SOURCE (UK) LTD TEL 01243-533900 FAX 01243-532949



INDUSTRIAL COMPUTER SOURCE®

Product Manual

MANUAL NO. 8701027

Revision L

SB486T2C/66

SB486TC/50

SB486TC/33

SB486SXTC/33

SB386SX/25



INDUSTRIAL COMPUTER SOURCE®

9950 Barnes Canyon Road, San Diego, CA 92121 (619) 677-0877 (FAX) 619-677-0895

INDUSTRIAL COMPUTER SOURCE EUROPE TEL (1) 69.18.74.30 FAX (1) 64.46.40.42
INDUSTRIAL COMPUTER SOURCE (UK) LTD TEL 01243-533900 FAX 01243-532949

This page intentionally left blank.

INDUSTRIAL COMPUTER SOURCE GUARANTEE, LIMITED WARRANTY AND RETURN POLICY

* **LIMITED WARRANTY:** One year limited warranty on all products sold with the exception of the "Performance Series" I/O products, which are warranted to the original purchaser for as long as they own the product, subject to all other conditions below, including those regarding neglect, misuse and acts of God. Within one year of purchase, we will repair or replace, at our option, any defective product sold by us. At any time after one year, we will repair or replace, at our option, any defective "Performance Series" I/O product sold by us. This does not include products damaged in shipment, or damaged through customer neglect or misuse.

The Return Procedure below must be followed to assure repair or replacement. We will normally return your replacement or repaired item via UPS Blue. Overnight delivery or delivery via other carriers is available at additional charge.

The limited warranty is void if the product has been subjected to alteration, neglect, misuse, or abuse; if any repairs have been attempted by anyone other than Industrial Computer Source or its authorized agent; or if the failure is caused by accident, acts of God, or other causes beyond the control of Industrial Computer Source or the manufacturer. Neglect, misuse, and abuse shall include any installation, operation, or maintenance of the product other than in accordance with the owners' manual.

No agent, dealer, distributor, service company, or other party is authorized to change, modify, or extend the terms of this Limited Warranty in any manner whatsoever. Industrial Computer Source reserves the right to make changes or improvements in any product without incurring any obligation to similarly alter products previously purchased.

* **GUARANTEE:** Thirty day money-back guarantee on all standard products sold. Special order products are covered by our Limited Warranty, however they may not be returned for refund or credit.

REFUNDS: In order to receive a full refund of product purchase price, the product must not have been damaged by the customer or by the common carrier chosen by the customer to return the goods, and the product must be returned complete (meaning all manuals, software, cables, etc.) within 30 days of receipt and in as-new and resalable con-

dition. RETURN PROCEDURE below must be followed to assure prompt refund.

RESTOCKING CHARGES: Product returns after 30 days, and before 90 days, after purchase will be subject to a minimum 20% restocking charge and any charges for damaged or missing parts.

Products not returned within 90 days of purchase, or products which are not in as-new and resalable condition, are not eligible for credit return and will be returned to the customer.

RETURN PROCEDURE: For any Limited Warranty or Guarantee return, every product returned to Industrial Computer Source for service or credit must be accompanied by a Return Material Authorization (RMA) Number, obtained from Industrial Computer Source Customer Service, **(800) 480-0044**, prior to its return. Freight on all returned items must be prepaid by the customer and customer is responsible for any loss or damage caused by common carrier in transit. Returns for warranty must include a failure report for each unit by serial number, as well as a copy of the original invoice showing date of purchase.

To reduce risk of damage, returns of product must be in an Industrial Computer Source shipping container. If the original container has been lost or damaged, new shipping containers may be obtained from Industrial Computer Source Customer Service at a nominal cost.

SHIPMENTS NOT IN COMPLIANCE WITH THIS GUARANTEE AND LIMITED WARRANTY RETURN POLICY WILL NOT BE ACCEPTED BY INDUSTRIAL COMPUTER SOURCE

LIMITATION OF LIABILITY: In no event shall Industrial Computer Source be liable for any defect in hardware or software or loss or inadequacy of data of any kind, or for any direct, indirect, incidental, or consequential damages in connection with or arising out of the performance or use of any product furnished hereunder. Industrial Computer Source liability shall in no event exceed the purchase price of the product purchased hereunder. The foregoing limitation of liability shall be equally applicable to any service provided by Industrial Computer Source or its authorized agent.

*** Some sale items and custom systems are not subject to the guarantee and limited warranty above, however in these instances any deviations will be disclosed prior to sale and noted on the original invoice. We reserve the right to refuse returns or refunds on software or special order items.**

FOREWORD

This instruction manual provides the necessary user information for the referenced product(s) manufactured or distributed by Industrial Computer Source for the user to install, operate and/or program the product properly. Please refer to the preceding pages for information regarding the warranty and repair policies.

Technical assistance is available at (800) 480-0044.

Manual Errors, Omissions and Bugs: A Bug Sheet is included as the last page of this manual. Please use it if you find a problem with the manual you believe should be corrected.

NOTICE

The information in this document is provided for reference only. Industrial Computer Source does not assume any liability arising out of the application or use of the information or products described herein. This document may contain or reference information and products protected by copyrights or patents and does not convey any license under the patent rights of Industrial Computer Source, nor the rights of others.

Printed in the U.S.A. Copyright 1996 by Industrial Computer Source, a California corporation, 9950 Barnes Canyon Road, San Diego, CA 92121. All rights reserved.

TRADEMARKS

IBM, PC/AT, VGA, EGA and PS/2 are trademarks of International Business Machines Corp.

AMI and AMIBIOS are trademarks of American Megatrends Inc.

Intel, 486, 386, DX and SX are trademarks of Intel Corporation

MS-DOS and Microsoft are trademarks of Microsoft Corp.

All other brand and product names are trademarks or registered trademarks of their respective companies.

LIABILITY DISCLAIMER

This manual is as complete and factual as possible at the time of printing; however, the information in this manual may have been updated since that time. Industrial Computer Source reserves the right to change the functions, features, or specifications of their products at any time, without notice.

TABLE OF CONTENTS

Specifications1-1

SB486T2C/66, SB486TC/50, SB486TC/33 and SB486SXTC/33 (C4DX)

Model Numbers	1-C4DX-1
Features	1-C4DX-1
Processor Block Diagram . . .	1-C4DX-3
Processor Board Layout	1-C4DX-4
Processor	1-C4DX-5
CPU Clock	1-C4DX-5
Bus Speed	1-C4DX-5
On-Board Features	1-C4DX-5
RAM Memory	1-C4DX-6
ROM Memory	1-C4DX-7
Performance	1-C4DX-7
Power Requirements	1-C4DX-7
Environment	1-C4DX-7
Configuration Jumpers	1-C4DX-8
System BIOS	1-C4DX-9
Watchdog Timer	1-C4DX-10
Connectors	1-C4DX-11

SB386SX/25 (C3SX)

Model Number	1-C3SX-1
Features	1-C3SX-1
Processor Block Diagram . . .	1-C3SX-3
Processor Board Layout	1-C3SX-4
Processor	1-C3SX-5
CPU Clock	1-C3SX-5
Bus Speed	1-C3SX-5
On-Board Features	1-C3SX-5

TABLE OF CONTENTS

Specifications (continued)	
RAM Memory	1-C3SX-5
ROM Memory	1-C3SX-6
Performance	1-C3SX-6
Power Requirements	1-C3SX-7
Environment	1-C3SX-7
Configuration Jumpers	1-C3SX-8
System BIOS	1-C3SX-9
Watchdog Timer	1-C3SX-9
Connectors	1-C3SX-11
ISA Reference	2-1
ISA Bus	2-1
I/O Address Map	2-8
Interrupt Assignments	2-8
System BIOS	3-1
BIOS Operation	3-1
Password Entry	3-3
BIOS Errors	3-5
Running the CMOS Setup Programs	3-7
BIOS Setup Menu	3-8
Change Password	3-13
Auto Detect Hard Disk	3-15
Key Conventions	3-18
Standard CMOS Setup/Drive Types	4-1

TABLE OF CONTENTS

Advanced Setup5-1
SB486T2C/66, SB486TC/50, SB486TC/33 and SB486SXTC/33 (C4DX)	
Advanced CMOS Setup . . .	5-C4DX-1
Advanced Chip Set Setup	5-C4DX-11
SB386SX/25 (C3SX)	
Advanced CMOS Setup . . .	5-C3SX-1
Advanced Chip Set Setup .	5-C3SX-9
Peripheral Management Setup6-1
Appendix A - BIOS Messages	A-1

This page intentionally left blank.

SPECIFICATIONS

This section contains features and technical data for each of the processor boards. The information is segmented into individual sections for each processor board.

Each section contains information about the following:

- Model Numbers
- Features
- Block Diagram
- Board Layout
- Electrical
- Environmental
- Switches/Jumpers
- Connectors

This page intentionally left blank.

INTRODUCTION - SB486T2C/66, SB486TC/50, SB486TC/33 and SB486SXTC/33

The SB486T2C/66, SB486TC/50 and SB486TC/33 (C4DX) and the SB486SXTC/33 full-featured ISA processors are single board computers which feature CPU, DRAM, floppy controller, IDE interface, two serial ports, parallel port, cache, upgrade socket, speaker port and keyboard port on a single ISA card. These single-slot, high performance processors plug into ISA Bus passive backplanes and provide 100% PC/AT compatibility for the system expansion slots.

MODEL NUMBERS

SB486T2C/66	486DX2 CPU at 66MHz with cache
SB486TC/50	486DX CPU at 50MHz with cache
SB486TC/33	486DX CPU at 33MHz with cache
SB486SXTC/33	486SX CPU at 33MHz with cache

FEATURES

- 80486DX2 microprocessor at 66MHz, or 80486DX microprocessor at 50MHz or 33MHz, or 80486SX microprocessor at 33MHz, each with 8KB Internal Cache Memory
- 128KB External Cache Memory
- Intel upgrade socket for next generation CPU upgrades
- Two serial ports and one parallel port
- Floppy drive and IDE drive interface
- Automatic or Manual Peripheral Configuration
- Supports up to 32MB of DRAM on-board in two 32-bit wide DRAM banks
- Supports 256K x 9, 1MB x 9 and 4MB x 9 SIMM's

FEATURES (continued)

- Shadow RAM for System BIOS and peripherals increases system speed and performance
- Selectable bus speed
- Watchdog timer
- On-board battery
- Enhanced ISA Bus drive capability to support 20-slot back-planes
- 64KB user EPROM space available
- Full PC/AT compatibility
- OPTI chip set

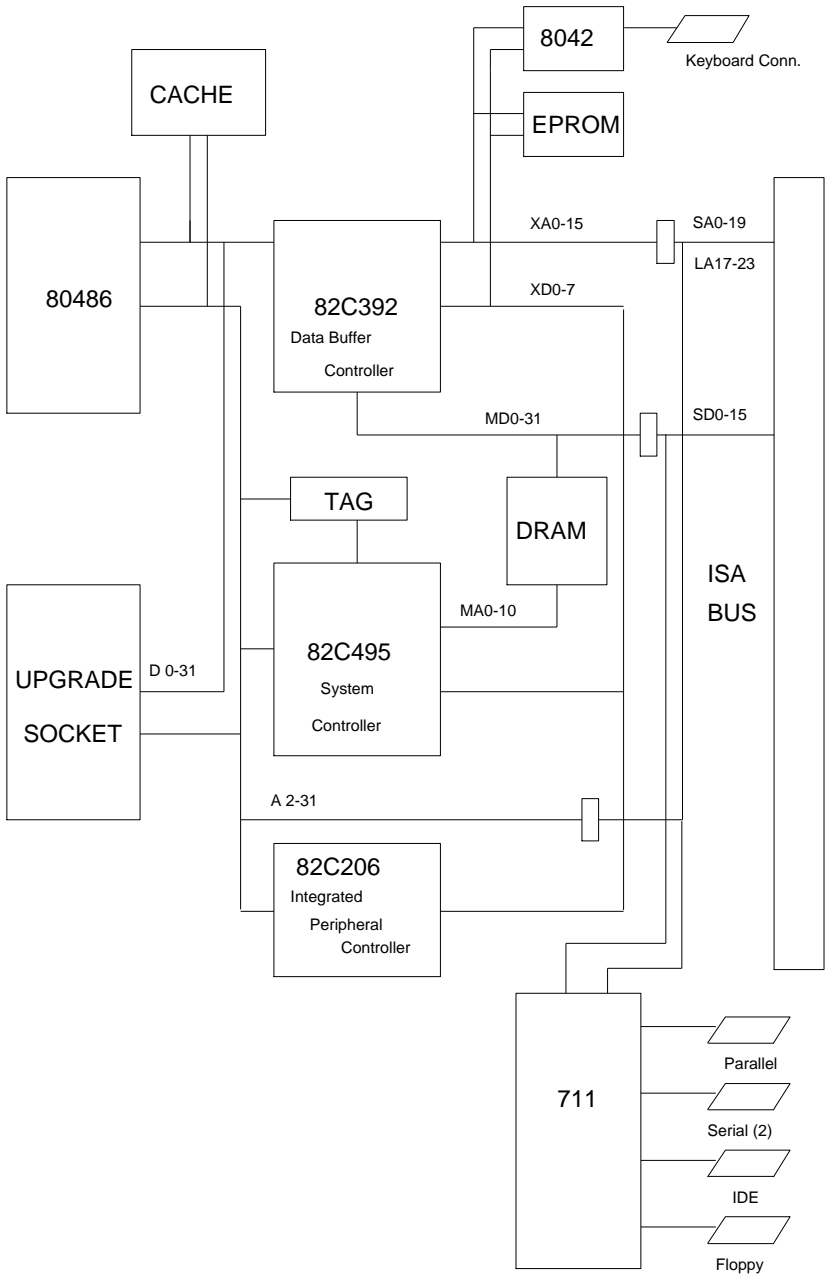

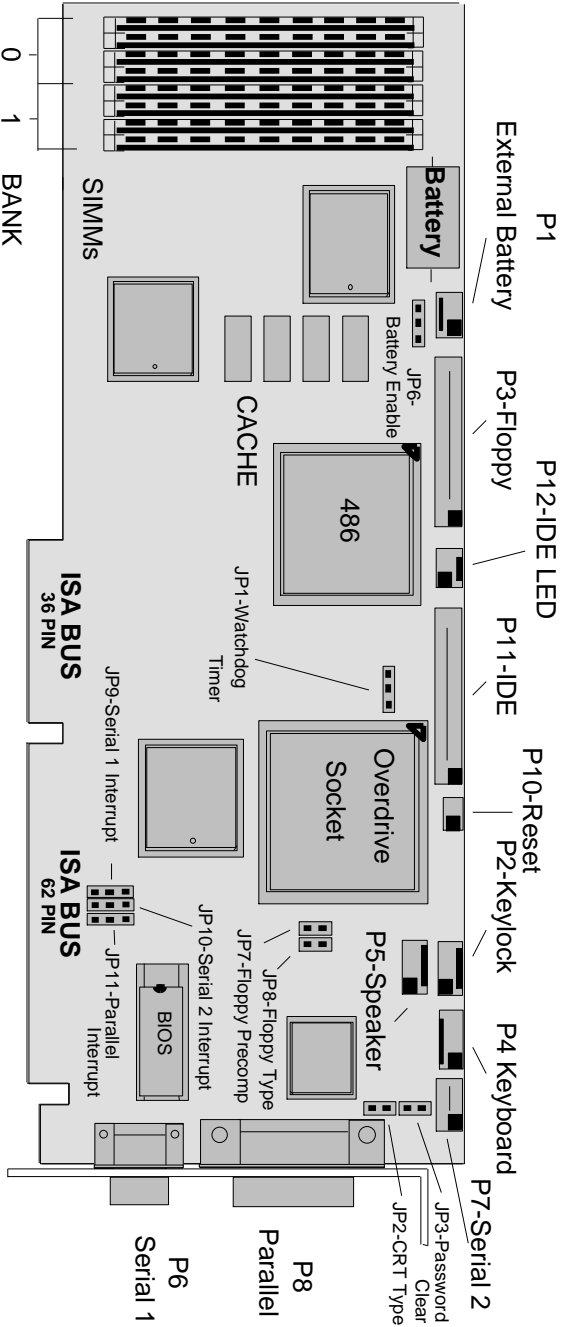

PROCESSOR

- 80486DX2 at 66MHz operation
- 80486DX at 50MHz or 33MHz operation
- 80486SX at 33MHz operation

CPU CLOCK

- 486DX2/66 - 33MHz
- 486DX/50 - 50MHz
- 486DX/33 - 33MHz
- 486SX/33 - 33MHz

BUS SPEED

- 8.25MHz default for 66MHz or 33MHz, selectable through BIOS Setup
- 8.33MHz default for 50MHz, selectable through BIOS Setup

ON-BOARD FEATURES

- Speaker port
- Keyboard port
- Keylock port
- Floppy disk controller supports two floppy drives. Drives can be 3-1/2" or 5-1/4" or one of each.
- Two serial ports
- Parallel printer port - bidirectional
- IDE interface supports two integrated drive electronics hard drives
- On-board battery

RAM MEMORY - 1 MB to 32 MB**Processor Board RAM Memory:**

- 1MB to 32MB memory on processor board
 - 1MB - 4 256K x 9 SIMM's
 - 2MB - 8 256K x 9 SIMM's
 - 4MB - 4 1MB x 9 SIMM's
 - 5MB - 4 256K x 9 SIMM's (Bank 0) and 4 1MB x 9 SIMM's (Bank 1)
 - 8MB - 8 1MB x 9 SIMM's
 - 16MB - 4 4MB x 9 SIMM's
 - 20MB - 4 1MB x 9 SIMM's (Bank 0) and 4 4MB x 9 SIMM's (Bank 1)
 - 32MB - 8 4MB x 9 SIMM's
-

NOTE: Four SIMM's of the same memory capacity must be used to fill a memory bank. For memory configurations requiring only four SIMM's, the SIMM's must be in Bank 0 (U40-U43).

- RAM Speed
 - 66MHz \leq 80 nanoseconds
 - 50MHz \leq 80 nanoseconds (CAS access must be \leq 25 nanoseconds)
 - 33MHz \leq 80 nanoseconds
 - \leq 60 nanoseconds without external cache

ROM MEMORY

- BIOS ROM memory on the processor board is 1 27C512 (64K x 8), 64KB user EPROM space available with optional 27C1001 (128K x 8)

PERFORMANCE

- Norton SI Version 6.0
 - 66MHz - 132.0
 - 50MHz - 107.9
 - 33MHz - 72.1

POWER REQUIREMENTS

Voltage:

- +5V @ 2.7 Amps typical (33MHz processor with cache)
- +12V @ < 100 mAmps typical
- 12V @ < 100 mAmps typical

ENVIRONMENT

Operating Temperature: 0° C to 60° C.

Storage Temperature: -20° C to 70° C.

Humidity Maximum: 90% non-condensing

CONFIGURATION JUMPERS

The setup of the configuration jumpers on the processor is described below. * indicates the default value of each jumper.

NOTE: For two-position jumpers (3-post), "RIGHT" is toward the bracket end of the board; "LEFT" is toward the memory sockets.

<u>Jumper</u>	<u>Description</u>
JP1	Watchdog Timer Install on the LEFT to enable watchdog timer operation. Install on the RIGHT for normal reset operation. *
JP2	CRT Type Select Install for a color CRT. * Remove for a monochrome CRT.
JP3	Password Clear Install for one power-up cycle to reset the password to the default (null password). Remove for normal operation. *
JP6	Battery Enable Install on the LEFT to use the on-board battery. * Install on the RIGHT to use an external battery.
JP7	Floppy Precompensation Select Install for normal. * Remove for alternate.
JP8	Floppy Drive Type Select Install for dual speed drives. Remove for single speed drives. *

CONFIGURATION JUMPERS (continued)

<u>Jumper</u>	<u>Description</u>
JP9	On-Board Serial Port 1 Interrupt Select Install on the TOP for IRQ4. * Install on the BOTTOM for IRQ3.
JP10	On-Board Serial Port 2 Interrupt Select Install on the TOP for IRQ4. Install on the BOTTOM for IRQ3. *
JP11	On-Board Parallel Port 1 Interrupt Select Install on the TOP for IRQ7. * Install on the BOTTOM for IRQ5.

SYSTEM BIOS

The System BIOS is an AMI Hi-Flex BIOS with ROM-resident setup utilities. The following Setup utilities are selectable from the main BIOS Setup Menu:

- Standard CMOS Setup
- Advanced CMOS Setup
- Advanced Chip Set Setup
- Peripheral Management Setup
- Auto Configuration with BIOS Defaults
- Change Password
- Auto Detect Hard Disk

WATCHDOG TIMER

The watchdog timer is a hardware timer that resets the processor board if the timer is not refreshed by software periodically. The timer is typically used to restart an application which becomes hung on an external event. When the application is hung, it can no longer refresh the timer. The watchdog timer then times out and resets the processor board.

The watchdog timer has two levels of enable. First, the watchdog timer jumper must be moved to the "enabled" position, which puts the watchdog timer under software control. Second, user-supplied software must start the watchdog timer via Keyboard Controller (8042) Port 2, bit 3 (P23). P23 is set high from reset. Setting P23 low starts the watchdog timer timeout of 1.2 seconds (nominal). Before the end of the timeout, P23 must be toggled high then low to restart the timeout. If P23 is left low until the end of the timeout, the watchdog timer issues a hardware reset to the processor board. The timer should be refreshed by the software every 1.0 seconds to prevent a timeout.

A set of watchdog timer software is available from Technical Support. The software includes sample C code which can be embedded in a user program and demo software to demonstrate and test the watchdog timer.

CONNECTORS

NOTE: Pin 1 on the connectors is indicated by the square pad on the PCB.

P1 - External Battery Connector for CMOS Memory

3 pin single row header, Amp #640456-3

<u>PIN</u>	<u>SIGNAL</u>
1	Positive
2	NC
3	Negative

P2 - Keylock Connector

5 pin single row header, Amp #640456-5

<u>PIN</u>	<u>SIGNAL</u>
1	LED Power
2	Key
3	Gnd
4	Keylock Data
5	Gnd

P3 - Floppy Drive Connector

34 pin dual row header, Molex #10-89-1341

<u>PIN</u>	<u>SIGNAL</u>	<u>PIN</u>	<u>SIGNAL</u>
1	Gnd	2	N-RPM
3	Gnd	4	NC
5	Gnd	6	NC
7	Gnd	8	P-Index
9	Gnd	10	N-Motoron 1
11	Gnd	12	N-Drive Sel2
13	Gnd	14	N-Drive Sel1
15	Gnd	16	N-Motoron 2
17	Gnd	18	N-Dir
19	Gnd	20	N-Stop Step

P3 - Floppy Drive Connector (continued)

<u>PIN</u>	<u>SIGNAL</u>	<u>PIN</u>	<u>SIGNAL</u>
21	Gnd	22	N-Write Data
23	Gnd	24	N-Write Gate
25	Gnd	26	P-Track 0
27	Gnd	28	P-Write Protect
29	Gnd	30	N-Read Data
31	Gnd	32	N-Side Select
33	Gnd	34	Disk Chng

P4 - Keyboard Connector

5 pin single row header, Amp #640456-5

<u>PIN</u>	<u>SIGNAL</u>
1	Kbd Clock
2	Kbd Data
3	Key
4	Kbd Gnd
5	Kbd Power (+5V fused)

P5 - Speaker Port Connector

4 pin single row header, Amp #640456-4

<u>PIN</u>	<u>SIGNAL</u>
1	Speaker Data
2	Key
3	Gnd
4	+5V

P6 - Serial Port 1 Connector

9 pin D, Amp #747840-3

<u>PIN</u>	<u>SIGNAL</u>	<u>PIN</u>	<u>SIGNAL</u>
1	Carrier Detect	6	Data Set Ready-I
2	Receive Data-I	7	Request to Send-O
3	Transmit Data-O	8	Clear to Send-I
4	Data Terminal Ready-O	9	Ring Indicator-I
5	Signal Gnd		

P7 - Serial Port 2 Connector

10 pin dual row header, Molex #10-89-1101

<u>PIN</u>	<u>SIGNAL</u>	<u>PIN</u>	<u>SIGNAL</u>
1	Carrier Detect	2	Data Set Ready-I
3	Receive Data-I	4	Request to Send-O
5	Transmit Data-O	6	Clear to Send-I
7	Data Terminal Ready-O	8	Ring Indicator-I
9	Signal Gnd	10	NC

P8 - Parallel Port Connector

25 pin D, Amp #747846-3

<u>PIN</u>	<u>SIGNAL</u>	<u>PIN</u>	<u>SIGNAL</u>
1	Strobe	14	Auto Feed XT
2	Data Bit 0	15	Error
3	Data Bit 1	16	Init
4	Data Bit 2	17	Slct In
5	Data Bit 3	18	Gnd
6	Data Bit 4	19	Gnd
7	Data Bit 5	20	Gnd
8	Data Bit 6	21	Gnd
9	Data Bit 7	22	Gnd
10	ACK	23	Gnd
11	Busy	24	Gnd
12	Paper End	25	Gnd
13	Slct		

P10 - External Reset Connector

2 pin header, Amp #640456-2

<u>PIN</u>	<u>SIGNAL</u>
1	Negative External Reset
2	Gnd

P11 - IDE Hard Drive Connector

40 pin dual row header, Molex #10-89-1401

<u>PIN</u>	<u>SIGNAL</u>	<u>PIN</u>	<u>SIGNAL</u>
1	Reset	2	Gnd
3	Data 7	4	Data 8
5	Data 6	6	Data 9
7	Data 5	8	Data 10
9	Data 4	10	Data 11
11	Data 3	12	Data 12
13	Data 2	14	Data 13
15	Data 1	16	Data 14
17	Data 0	18	Data 15
19	Gnd	20	NC
21	NC	22	Gnd
23	IOW	24	Gnd
25	IOR	26	Gnd
27	NC	28	ALE
29	NC	30	Gnd
31	IRQ 14	32	IOCS16
33	Add 1	34	NC
35	Add 0	36	Add 2
37	CS 0	38	CS 1
39	Light	40	Gnd

P12 - IDE Hard Drive LED Connector

4 pin single row header, Amp #640456-4

<u>PIN</u>	<u>SIGNAL</u>
1	+5V Pullup
2	Light
3	Light
4	+5V Pullup

INTRODUCTION - SB386SX/25

The SB386SX/25 (C3SX) full-featured ISA processor is a single board computer which features CPU, DRAM, floppy controller, IDE interface, two serial ports, parallel port, coprocessor socket, speaker port and keyboard port on a single ISA card. This single-slot, high performance processor plugs into ISA Bus passive backplanes and provides 100% PC/AT compatibility for the system expansion slots.

MODEL NUMBER

SB386SX/25

386SX CPU at 25MHz

FEATURES

- 80386SX microprocessor at 25MHz
- Two serial ports and one parallel port
- Floppy drive and IDE drive interface
- Automatic or Manual Peripheral Configuration
- Coprocessor socket
- Selectable bus speed
- 64KB user EPROM space available
- Watchdog timer
- Supports up to 16MB of DRAM on-board
- Supports 256K x 9, 1MB x 9 and 4MB x 9 SIMM's
- Shadow RAM for System BIOS and peripherals increases system speed and performance
- Chips and Technologies Peak SX PC/AT Chip Set

C
3
S
X

This page intentionally left blank.

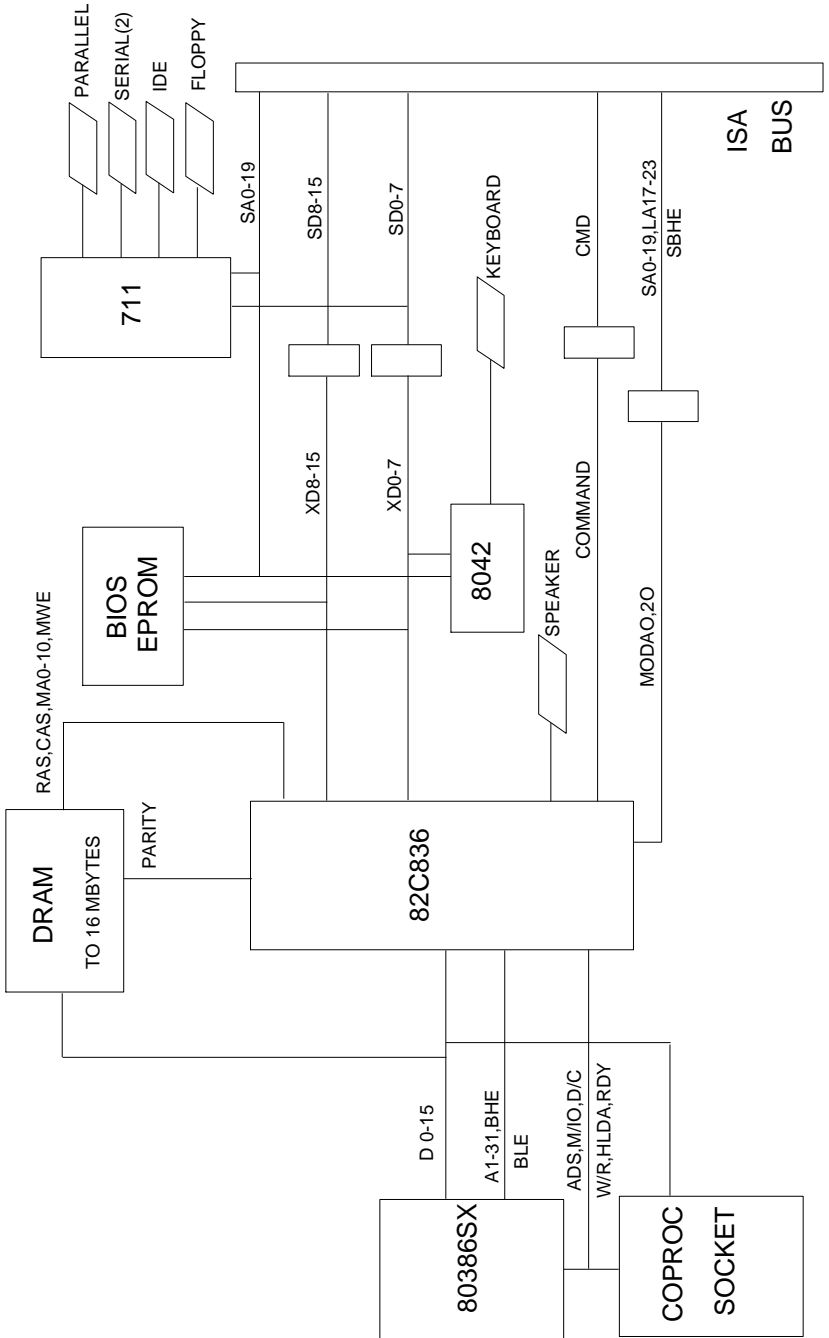

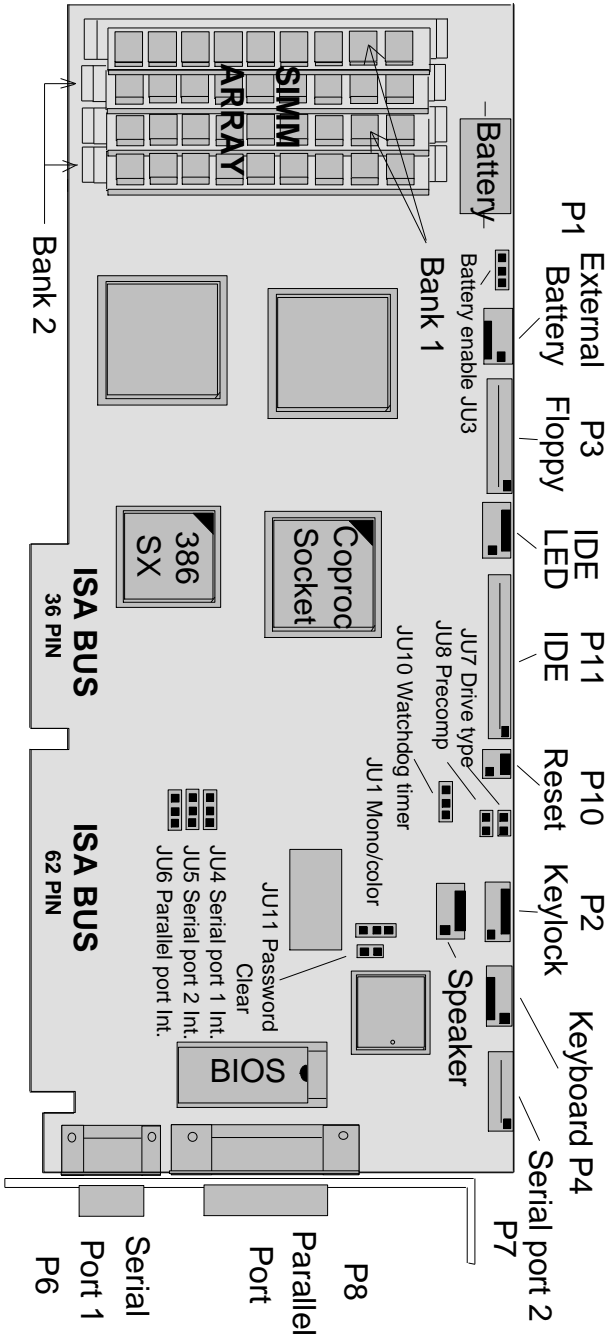

PROCESSOR

- 80386SX

CPU CLOCK

- 25MHz

BUS SPEED

- 8.33MHz default, selectable through BIOS Setup

ON-BOARD FEATURES

- Speaker port
- Keyboard port
- Floppy disk controller supports two floppy drives. Drives can be 3-1/2" or 5-1/4" or one of each.
- Two serial ports
- Parallel printer port - bidirectional
- IDE interface supports two integrated drive electronics hard drives
- On-board battery

RAM MEMORY - 1 MB to 16 MB

Processor Board RAM Memory:

- 1MB to 16MB memory on processor board
 - 1MB - 4 256K x 9 SIMM's
 - 2MB - 2 1MB x 9 SIMM's
 - 4MB - 4 1MB x 9 SIMM's
 - 8MB - 2 4MB x 9 SIMM's, install in Bank 2

Processor Board RAM Memory (continued):

- 10MB - 2 1MB x 9 (Bank 1) and 2 4MB x 9 (Bank 2) SIMM's
 - 16MB - 4 4MB x 9 SIMM's
-

NOTE: Two SIMM's of the same memory capacity must be used to fill a memory bank. Bank 1 (U18 and U20) must be filled before Bank 2 (U19 and U21), except in the 8MB configuration.

NOTE: The top 128KB of the 16MB address space is mapped to the High ROM area. Therefore, on a 16MB system, this area is not available as RAM.

- RAM Speed
 - ≤ 60 nanoseconds, 0 wait state or ≤ 80 nanoseconds, 1 wait state. (For Additional RAM Wait State for 25MHz/80 ns. operation, see the *Advanced Setup* section of this manual.)

ROM MEMORY

- BIOS ROM memory on the processor board is 1 27C512 (64K x 8); 64K user EPROM available with optional 27C1010 (128K x 8).

PERFORMANCE

- Norton SI Version 6.0
 - 25MHz - 17.5

POWER REQUIREMENTS

Voltage:

- +5V @ 1.3 Amps typical
- +12V @ < 100 mAmps typical
- 12V @ < 100 mAmps typical

ENVIRONMENT

Operating Temperature: 0° C to 60° C.

Storage Temperature: -20° C to 70° C.

Humidity Maximum: 90% non-condensing

CONFIGURATION JUMPERS

The setup of the configuration jumpers on the processor is described below. * indicates the default value of each jumper.

NOTE: For two-position jumpers (3-post), "RIGHT" is toward the bracket end of the board; "LEFT" is toward the memory sockets.

<u>Jumper</u>	<u>Description</u>
JU1	CRT Type Select Install on the TOP for a color CRT. * Install on the BOTTOM for a monochrome CRT.
JU3	Battery Enable Install on the LEFT to use the on-board battery. * Install on the RIGHT to use an external battery.
JU4	On-Board Serial Port 1 Interrupt Select Install on the LEFT for IRQ3. Install on the RIGHT for IRQ4. *
JU5	On-Board Serial Port 2 Interrupt Select Install on the LEFT for IRQ3. * Install on the RIGHT for IRQ4.
JU6	On-Board Parallel Port 1 Interrupt Select Install on the LEFT for IRQ5. Install on the RIGHT for IRQ7. *
JU7	Floppy Drive Type Select Install for dual speed drives. Remove for single speed drives. *
JU8	Floppy Precompensation Select Install for normal. * Remove for alternate.

CONFIGURATION JUMPERS (continued)

<u>Jumper</u>	<u>Description</u>
JU10	Watchdog Timer Install on the LEFT to enable the watchdog timer. Install on the RIGHT for normal reset operation. *
JU11	Password Clear Install for one power-up cycle to reset the password to the default (null password). Remove for normal operation. *

SYSTEM BIOS

The System BIOS is an AMI Hi-Flex BIOS with ROM-resident setup utilities. The following Setup utilities are selectable from the main BIOS Setup Menu:

- Standard CMOS Setup
- Advanced CMOS Setup
- Advanced Chip Set Setup
- Peripheral Management Setup
- Change Password
- Auto Configuration with BIOS Defaults

WATCHDOG TIMER

The watchdog timer is a hardware timer that resets the processor board if the timer is not refreshed by software periodically. The timer is typically used to restart an application which becomes hung on an external event. When the application is hung, it can no longer refresh the timer. The watchdog timer then times out and resets the processor board.

The watchdog timer has two levels of enable. First, the watchdog timer jumper must be moved to the "enabled" position, which puts the watchdog timer under software control. Second, user-supplied software must start the watchdog timer via Keyboard Controller (8042) Port 2, bit 3 (P23). P23 is set high from reset. Setting P23 low starts the watchdog timer timeout of 1.2 seconds (nominal). Before the end of the timeout, P23 must be toggled high then low to restart the timeout. If P23 is left low until the end of the timeout, the watchdog timer issues a hardware reset to the processor board. The timer should be refreshed by the software every 1.0 seconds to prevent a timeout.

A set of watchdog timer software is available from Technical Support. The software includes sample C code which can be embedded in a user program and demo software to demonstrate and test the watchdog timer.

CONNECTORS

NOTE: Pin 1 on the connectors is indicated by the square pad on the PCB.

P1 - External Battery Connector for CMOS Memory

3 pin single row header, Amp #640456-3

<u>PIN</u>	<u>SIGNAL</u>
1	Positive
2	NC
3	Negative

P2 - Keylock Connector

5 pin single row header, Amp #640456-5

<u>PIN</u>	<u>SIGNAL</u>
1	LED Power
2	Key
3	Gnd
4	Keylock Data
5	Gnd

P3 - Floppy Drive Connector

34 pin dual row header, Molex #10-89-1341

<u>PIN</u>	<u>SIGNAL</u>	<u>PIN</u>	<u>SIGNAL</u>
1	Gnd	2	N-RPM
3	Gnd	4	NC
5	Gnd	6	NC
7	Gnd	8	P-Index
9	Gnd	10	N-Motoron 1
11	Gnd	12	N-Drive Sel2
13	Gnd	14	N-Drive Sel1
15	Gnd	16	N-Motoron 2
17	Gnd	18	N-Dir
19	Gnd	20	N-Stop Step
21	Gnd	22	N-Write Data

C
3
S
X

P3 - Floppy Drive Connector (continued)

<u>PIN</u>	<u>SIGNAL</u>	<u>PIN</u>	<u>SIGNAL</u>
23	Gnd	24	N-Write Gate
25	Gnd	26	P-Track 0
27	Gnd	28	P-Write Protect
29	Gnd	30	N-Read Data
31	Gnd	32	N-Side Select
33	Gnd	34	Disk Chng

P4 - Keyboard Connector

5 pin single row header, Amp #640456-5

<u>PIN</u>	<u>SIGNAL</u>
1	Kbd Clock
2	Kbd Data
3	Key
4	Kbd Gnd
5	Kbd Power (+5V fused)

P5 - Speaker Port Connector

4 pin single row header, Amp #640456-4

<u>PIN</u>	<u>SIGNAL</u>
1	Speaker Data
2	Key
3	Gnd
4	+5V

P6 - Serial Port 1 Connector

9 pin D, Amp #747840-3

<u>PIN</u>	<u>SIGNAL</u>	<u>PIN</u>	<u>SIGNAL</u>
1	Carrier Detect	6	Data Set Ready-I
2	Receive Data-I	7	Request to Send-O
3	Transmit Data-O	8	Clear to Send-I
4	Data Terminal Ready-O	9	Ring Indicator-I
5	Signal Gnd		

P7 - Serial Port 2 Connector

10 pin dual row header, Molex #10-89-1101

<u>PIN</u>	<u>SIGNAL</u>	<u>PIN</u>	<u>SIGNAL</u>
1	Carrier Detect	2	Data Set Ready-I
3	Receive Data-I	4	Request to Send-O
5	Transmit Data-O	6	Clear to Send-I
7	Data Terminal Ready-O	8	Ring Indicator-I
9	Signal Gnd	10	NC

P8 - Parallel Port Connector

25 pin D, Amp #747846-3

<u>PIN</u>	<u>SIGNAL</u>	<u>PIN</u>	<u>SIGNAL</u>
1	Strobe	14	Auto Feed XT
2	Data Bit 0	15	Error
3	Data Bit 1	16	Init
4	Data Bit 2	17	Slct In
5	Data Bit 3	18	Gnd
6	Data Bit 4	19	Gnd
7	Data Bit 5	20	Gnd
8	Data Bit 6	21	Gnd
9	Data Bit 7	22	Gnd
10	ACK	23	Gnd
11	Busy	24	Gnd
12	Paper End	25	Gnd
13	Slct		

P10 - External Reset Connector

2 pin header, Amp #640456-2

<u>PIN</u>	<u>SIGNAL</u>
1	Negative External Reset
2	Gnd

P11 - IDE Hard Drive Connector

40 pin dual row header, Molex #10-89-1401

<u>PIN</u>	<u>SIGNAL</u>	<u>PIN</u>	<u>SIGNAL</u>
1	Reset	2	Gnd
3	Data 7	4	Data 8
5	Data 6	6	Data 9
7	Data 5	8	Data 10
9	Data 4	10	Data 11
11	Data 3	12	Data 12
13	Data 2	14	Data 13
15	Data 1	16	Data 14
17	Data 0	18	Data 15
19	Gnd	20	NC
21	NC	22	Gnd
23	IOW	24	Gnd
25	IOR	26	Gnd
27	NC	28	ALE
29	NC	30	Gnd
31	IRQ 14	32	IOCS16
33	Add 1	34	NC
35	Add 0	36	Add 2
37	CS 0	38	CS 1
39	Light	40	Gnd

P12 - IDE Hard Drive LED Connector

4 pin single row header, Amp #640456-4

<u>PIN</u>	<u>SIGNAL</u>
1	+5V Pullup
2	Light
3	Light
4	+5V Pullup

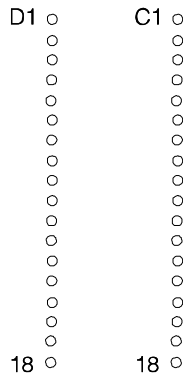
ISA BUS PIN NUMBERING**62-pin ISA Bus
Connector**Component Side
of Board**36-pin ISA Bus
Connector**

ISA BUS PIN ASSIGNMENTS

The following figures summarize pin assignments for the Industry Standard Architecture (ISA) Bus connectors.

I/O Pin	Signal Name	I/O
A1	IOCHK#	I
A2	D7	I/O
A3	D6	I/O
A4	D5	I/O
A5	D4	I/O
A6	D3	I/O
A7	D2	I/O
A8	D1	I/O
A9	D0	I/O
A10	CHRDY	I
A11	AEN	O
A12	SA19	I/O
A13	SA18	I/O
A14	SA17	I/O
A15	SA16	I/O
A16	SA15	I/O
A17	SA14	I/O
A18	SA13	I/O
A19	SA12	I/O
A20	SA11	I/O
A21	SA10	I/O
A22	SA9	I/O
A23	SA8	I/O
A24	SA7	I/O
A25	SA6	I/O
A26	SA5	I/O
A27	SA4	I/O
A28	SA3	I/O
A29	SA2	I/O
A30	SA1	I/O
A31	SA0	I/O

I/O Pin	Signal Name	I/O
B1	Gnd	Ground
B2	RESDRV	O
B3	+5V	Power
B4	IRQ9	I
B5	-5V	Power
B6	DRQ2	I
B7	-12V	Power
B8	NOWS#	I
B9	+12V	Power
B10	Gnd	Ground
B11	SMWTC#	O
B12	SMRDC#	O
B13	IOWC#	I/O
B14	IORC#	I/O
B15	DAK3#	O
B16	DRQ3	I
B17	DAK1#	O
B18	DRQ1	I
B19	REFRESH#	I/O
B20	BCLK	O
B21	IRQ7	I
B22	IRQ6	I
B23	IRQ5	I
B24	IRQ4	I
B25	IRQ3	I
B26	DAK2#	O
B27	T-C	O
B28	BALE	O
B29	+5V	Power
B30	OSC	O
B31	Gnd	Ground

ISA BUS PIN ASSIGNMENTS (continued)

I/O Pin	Signal Name	I/O
C1	SBHE#	I/O
C2	LA23	I/O
C3	LA22	I/O
C4	LA21	I/O
C5	LA20	I/O
C6	LA19	I/O
C7	LA18	I/O
C8	LA17	I/O
C9	MRDC#	I/O
C10	MWTC#	I/O
C11	D8	I/O
C12	D9	I/O
C13	D10	I/O
C14	D11	I/O
C15	D12	I/O
C16	D13	I/O
C17	D14	I/O
C18	D15	I/O

I/O Pin	Signal Name	I/O
D1	M16#	I
D2	IO16#	I
D3	IRQ10	I
D4	IRQ11	I
D5	IRQ12	I
D6	IRQ15	I
D7	IRQ14	I
D8	DAK0#	O
D9	DRQ0	I
D10	DAK5#	O
D11	DRQ5	I
D12	DAK6#	O
D13	DRQ6	I
D14	DAK7#	O
D15	DRQ7	I
D16	+5V	Power
D17	Master16#	I
D18	Gnd	Ground

ISA BUS SIGNAL DESCRIPTIONS

The following is a description of the ISA Bus signals. All signal lines are TTL-compatible.

AEN (O)

Address Enable (AEN) is used to degate the microprocessor and other devices from the I/O channel to allow DMA transfers to take place. When this line is active, the DMA controller has control of the address bus, the data-bus Read command lines (memory and I/O), and the Write command lines (memory and I/O).

BALE (O) (Buffered)

Address Latch Enable (BALE) is provided by the bus controller and is used on the system board to latch valid addresses and memory decodes from the microprocessor. It is available to the I/O channel as an indicator of a valid microprocessor or DMA address (when used with AEN). Microprocessor addresses SA[19::0] are latched with the falling edge of BALE. BALE is forced high during DMA cycles.

BCLK (O)

BCLK is the system clock. The clock has a 50% duty cycle. This signal should only be used for synchronization. It is not intended for uses requiring a fixed frequency.

CHRDY (I)

I/O Channel Ready (CHRDY) is pulled low (not ready) by a memory or I/O device to lengthen I/O or memory cycles. Any slow device using this line should drive it low immediately upon detecting its valid address and a Read or Write command. Machine cycles are extended by an integral number of clock cycles. This signal should be held low for no more than 2.5 microseconds.

D[15::0] (I/O)

Data signals D[15::0] provide bus bits 15 through 0 for the microprocessor, memory, and I/O devices. D15 is the most-significant bit and D0 is the least-significant bit. All 8-bit devices on the I/O channel should use D[7::0] for communications to the microprocessor. The 16-bit devices will use D[15::0]. To support 8-bit devices, the data on D[15::8] will be gated to D[7::0] during 8-bit transfers to these devices. 16-bit microprocessor transfers to 8-bit devices will be converted to two 8-bit transfers.

DAK[7::5]#, DAK[3::0]# (O)

DMA Acknowledge DAK[7::5]# and DAK[3::0]# are used to acknowledge DMA requests DRQ[7::5] and DRQ[3::0]. They are active low.

DRQ[7::5], DRQ[3::0] (I)

DMA Requests DRQ[7::5] and DRQ[3::0] are asynchronous channel requests used by peripheral devices and the I/O channel microprocessors to gain DMA service (or control of the system). They are prioritized, with DRQ0 having the highest priority and DRQ7 having the lowest. A request is generated by bringing a DRQ line to an active level. A DRQ line must be held high until the corresponding DMA Request Acknowledge (DAK) line goes active. DRQ[3::0] will perform 8-bit DMA transfers; DRQ[7::5] will perform 16-bit transfers.

IO16# (I)

I/O 16-bit Chip Select (IO16#) signals the system board that the present data transfer is a 16-bit, 1 wait-state, I/O cycle. It is derived from an address decode. IO16# is active low and should be driven with an open collector or tri-state driver capable of sinking 20 mAmps.

IOCHK# (I)

I/O Channel Check (IOCHK#) provides the system board with parity (error) information about memory or devices on the I/O channel. When this signal is active, it indicates an uncorrectable system error.

IORC# (I/O)

I/O Read (IORC#) instructs an I/O device to drive its data onto the data bus. It may be driven by the system microprocessor or DMA controller, or by a microprocessor or DMA controller resident on the I/O channel. This signal is active low.

IOWC# (I/O)

I/O Write (IOWC#) instructs an I/O device to read the data on the data bus. It may be driven by any microprocessor or DMA controller in the system. This signal is active low.

IRQ[15::14], IRQ[12::9], IRQ[7::3] (I)

Interrupt Requests IRQ[15::14], IRQ[12::9] and IRQ[7::3] are used to signal the microprocessor that an I/O device needs attention. The interrupt requests are prioritized, with IRQ[15::14] and IRQ[12::9] having the highest priority (IRQ9 is the highest) and IRQ[7::3] having the lowest priority (IRQ7 is the lowest). An interrupt request is generated when an IRQ line is raised from low to high. The line must be held high until the microprocessor acknowledges the interrupt request (Interrupt Service routine).

LA[23::17] (I/O)

These signals (unlatched) are used to address memory and I/O devices within the system. They give the system up to 16MB of addressability. These signals are valid when BALE is high. LA[23::17] are not latched during microprocessor cycles and therefore do not stay valid for the whole cycle. Their purpose is to generate memory decodes for 1 wait-state memory cycles. These decodes should be latched by I/O adapters on the falling edge of BALE. These signals

also may be driven by other microprocessors or DMA controllers that reside on the I/O channel.

M16# (I)

M16# Chip Select signals the system board if the present data transfer is a 1 wait-state, 16-bit, memory cycle. It must be derived from the decode of LA[23::17]. M16# should be driven with an open collector or tri-state driver capable of sinking 20 mAmps.

Master16# (I)

Master16# is used with a DRQ line to gain control of the system. A processor or DMA controller on the I/O channel may issue a DRQ to a DMA channel in cascade mode and receive a DAK#. Upon receiving the DAK#, an I/O microprocessor may pull Master16# low, which will allow it to control the system address, data, and control lines (a condition known as tri-state). After Master16# is low, the I/O microprocessor must wait one system clock period before driving the address and data lines, and two clock periods before issuing a Read or Write command. If this signal is held low for more than 15 microseconds, system memory may be lost because of a lack of refresh.

NOWS# (I)

The No Wait State (NOWS#) signal tells the microprocessor that it can complete the present bus cycle without inserting any additional wait cycles. In order to run a memory cycle to a 16-bit device without wait cycles, NOWS# is derived from an address decode gated with a Read or Write command. In order to run a memory cycle to an 8-bit device with a minimum of two wait states, NOWS# should be driven active on system clock after the Read or Write command is active gated with the address decode for the device. Memory Read and Write commands to a 8-bit device are active on the falling edge of the system clock. NOWS# is active low and should be driven with an open collector or tri-state driver capable of sinking 20 mAmps.

OSC (O)

Oscillator (OSC) is a high-speed clock with a 70-nanosecond period (14.31818 MHz). This signal is not synchronous with the system clock. It has a 50% duty cycle.

REFRESH# (I/O)

The REFRESH# signal is used to indicate a refresh cycle and can be driven by a microprocessor on the I/O channel.

RESDRV (O)

Reset Drive (RESDRV) is used to reset or initialize system logic at power-up time or during a low line-voltage outage. This signal is active high.

SA[19::0] (I/O)

Address bits SA[19::0] are used to address memory and I/O devices within the system. These twenty address lines, in addition to LA[23::17], allow access

of up to 16MB of memory. SA[19::0] are gated on the system bus when BALE is high and are latched on the falling edge of BALE. These signals are generated by the microprocessor or DMA Controller. They also may be driven by other microprocessors or DMA controllers that reside on the I/O channel.

SBHE# (I/O)

System Bus High Enable (SBHE#) indicates a transfer of data on the upper byte of the data bus, D[15::8]. 16-bit devices use SBHE# to condition data bus buffers tied to D[15::8].

SMRDC# (O), MRDC# (I/O)

These signals instruct the memory devices to drive data onto the data bus. SMRDC# is active only when the memory decode is within the low 1MB of memory space. MRDC# is active on all memory read cycles. MRDC# may be driven by any microprocessor or DMA controller in the system. SMRDC is derived from MRDC# and the decode of the low 1MB of memory. When a microprocessor on the I/O channel wishes to drive MRDC#, it must have the address lines valid on the bus for one system clock period before driving MRDC# active. Both signals are active low.

SMWTC# (O), MWTC# (I/O)

These signals instruct the memory devices to store the data present on the data bus. SMWTC# is active only when the memory decode is within the low 1MB of the memory space. MWTC# is active on all memory write cycles. MWTC# may be driven by any microprocessor or DMA controller in the system. SMWTC# is derived from MWTC# and the decode of the low 1MB of memory. When a microprocessor on the I/O channel wishes to drive MWTC#, it must have the address lines valid on the bus for one system clock period before driving MWTC# active. Both signals are active low.

T-C (O)

Terminal Count (T-C) provides a pulse when the terminal count for any DMA channel is reached.

I/O ADDRESS MAP

Hex Range	Device
000-01F	DMA Controller 1
020-03F	Interrupt Controller 1, Master
040-05F	Timer
060-06F	8042 (Keyboard)
070-07F	Realtime Clock, NMI (non-maskable interrupt) Mask
080-09F	DMA Page Register
0A0-0BF	Interrupt Controller 2
0C0-0DF	DMA Controller 2
0F0	Clear Math Coprocessor Busy
0F1	Reset Math Coprocessor
0F8-0FF	Math Coprocessor
1F0-1F8	Fixed Disk
200-207	Game I/O
278-27F	Parallel Printer Port 2
2F8-2FF	Serial Port 2
300-31F	Prototype Card
360-36F	Reserved
378-37F	Parallel Printer Port 1
380-38F	SDLC, Bisynchronous 2
3A0-3AF	Bisynchronous 1
3B0-3BF	Monochrome Display and Printer Adapter
3C0-3CF	Reserved
3D0-3DF	Color/Graphics Monitor Adapter
3F0-3F7	Diskette Controller
3F8-3FF	Serial Port 1

INTERRUPT ASSIGNMENTS

Interrupt	Description
IRQ0	Timer Output 0
IRQ1	Keyboard (Output Buffer Full)
IRQ2	Interrupt 8 through 15
IRQ3	Serial Port 2
IRQ4	Serial Port 1
IRQ5	Parallel Port 2
IRQ6	Diskette Controller
IRQ7	Parallel Port 1
IRQ8	Realtime Clock Interrupt
IRQ9	Software Redirected to INT 0AH (IRQ2)
IRQ10	Unassigned
IRQ11	Unassigned
IRQ12	Unassigned
IRQ13	Coprocessor
IRQ14	Fixed Disk Controller
IRQ15	Unassigned

BIOS OPERATION

Sections 3 through 6 of this manual describe the operation of the BIOS and BIOS Setup for processor boards which use the AMI Hi-Flex System BIOS. Refer to *Running the BIOS Setup Programs* later in this section for standard Setup screens, options and defaults. The available Setup screens, options and defaults may vary for your processor board.

When the system is powered on, the BIOS performs the Power-On Self Test (POST) routines. These routines are divided into two phases:

- 1) **System Test and Initialization.** Test and initialize system boards for normal operations.
- 2) **System Configuration Verification.** Compare defined configuration with hardware actually installed.

If an error is encountered during the diagnostic tests, the error is reported in one of two different ways. If the error occurs before the display device is initialized, a series of beeps is transmitted. If the error occurs after the display device is initialized, the error message is displayed on the screen. See *BIOS Errors* later in this section for more information on possible errors.

The following are the Power-On Self Tests (POST's) which are performed when the system is powered on:

- Processor Register Test
- ROM BIOS Checksum Check
- Keyboard Controller Test
- CMOS Shutdown Register Test
- Channel 2, 1, 0 Timer Test
- Memory Refresh Test
- Base 64KB RAM Test
- CMOS Battery, Options Set, Checksum Check

- Display Type Verification
- Entering Protected Mode
- Address Line Test and Memory Size Finding
- Conventional and Extended Memory Test
- DMA Controller Test
- Keyboard Test
- System Configuration Verification and Setup

NOTE: When you perform a warm boot by pressing <Ctrl><Alt>, all memory tests are bypassed.

The BIOS attempts to initialize the peripheral devices by verifying the validity of the system setup information stored in the system CMOS RAM. (See the *Running the CMOS Setup Programs* section of this manual.) If the BIOS detects a fault, the screen displays the error condition(s) which has/have been detected. If no errors are detected, the BIOS attempts to load the system from any bootable device, such as a floppy disk or hard disk.

Normally, the only POST routine visible on the screen is the memory test. The following screen displays when the system is powered on:

```
AMIBIOS (C)1994 American Megatrends Inc.  
INDUSTRIAL COMPUTER SOURCE  
XXXXXX
```

```
Hit DEL if you want to run SETUP
```

Initial Power-On Screen

You have two options:

- Press to access the System BIOS Setup program.

This option allows you to change various system parameters such as date and time, disk drives, video display, etc. The *Running the CMOS Setup Programs* section of this manual describes the options available.

You may be requested to enter a password before gaining access to the BIOS Setup program. (See *Password Entry* later in this section.)

If you enter the correct password or no password is required, the BIOS Setup Menu displays. (See *Running The CMOS Setup Programs* later in this section.)

- Allow the bootup process to continue without invoking the System BIOS Setup program.

In this case, after the BIOS loads the system, you may be requested to enter a password.

Password Entry

The system may be configured so that the user is required to enter a password each time the system boots or whenever an attempt is made to enter the Setup programs. The password function may also be disabled so that the password prompt will not appear under any circumstances.

The Password Checking Option in the Advanced CMOS Setup program allows you to specify when the password prompt will display: **Always** or only when **Setup** is attempted. The password may be changed using the Change Password option on the BIOS Setup Menu. If the password is null, the password prompt will not display at any time. A more detailed description of the password setup function may be found in the *Running the CMOS Setup Programs* section of this manual.

When password checking is enabled, the following password prompt displays:

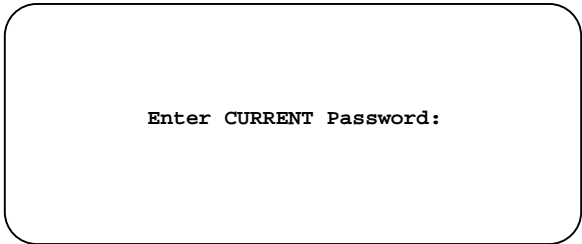

Type the password and press <Enter>.

NOTE: The null password is the system default and is in effect if a password has not been assigned or if the CMOS is corrupted. In this case, the password prompt does not display. To set up a password, you may use the Change Password function of the BIOS Setup Menu. (See the *Running the CMOS Setup Programs* section of this manual.)

If an incorrect password is entered, the following screen displays:

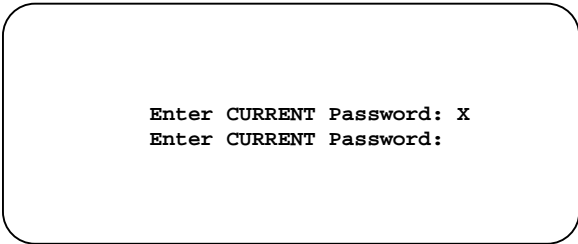

You may try again to enter the correct password. If you enter the password incorrectly three times, the system responds in one of two different ways, depending on the value specified in the Password Checking Option on the Advanced CMOS Setup screen. (See the *Running the CMOS Setup Programs* section of this manual for a description of this option.)

- 1) If the Password Checking Option is set to **Setup**, the system does not let you enter Setup, but does continue the booting process. You must reboot the system manually to retry entering the password.
- 2) If the Password Checking Option is set to **Always**, the system locks and you must reboot. After rebooting, you will be requested to enter the password.

Once the password has been entered correctly, you are allowed to continue.

BIOS Errors

If an error is encountered during the diagnostic checks performed when the system is powered on, the error is reported in one of two different ways:

- 1) If the error occurs before the display device is initialized, a series of beeps is transmitted.
- 2) If the error occurs after the display device is initialized, the screen displays the error message. In the case of a non-fatal error, a prompt to press the <F1> key may also appear on the screen.

Explanations of the beep codes and BIOS error messages may be found in *Appendix A - BIOS Messages*.

As the POST routines are performed, test codes are presented on Port 80H. These codes may be helpful as a diagnostic tool and are listed in *Appendix A - BIOS Messages*.

If any of the following error conditions is detected by the BIOS during the POST routines, you will be asked to run the Setup utility:

- CMOS battery state low
- CMOS system options not set
- CMOS checksum failure

- CMOS memory size mismatch
- CMOS time & date not set
- CMOS display type mismatch
- C: drive failure

These error messages are followed by this screen:

```
AMIBIOS (C)1994 American Megatrends Inc.  
INDUSTRIAL COMPUTER SOURCE  
XXXXXX
```

```
RUN SETUP UTILITY  
Press F1 to RESUME
```

NOTE: Pausing the system after a non-fatal error may be bypassed by disabling the "Wait for "F1" If Any Error" option in the Advanced Setup program. See the *Advanced Setup* section of this manual.

Press <F1>. You may be requested to enter a password before gaining access to the BIOS Setup program. (See *Password Entry* earlier in this section.)

If you enter the correct password or no password is required, the BIOS Setup Menu displays.

RUNNING THE CMOS SETUP PROGRAMS

The Setup programs keep a record of the system parameters, such as memory amounts, disk drives, video display, and numeric coprocessors. Setup resides in the Read Only Memory Basic Input/Output System (ROM BIOS) so that it is available each time the system is turned on. Setup stores the information in the complementary metal oxide semiconductor (CMOS) memory. When the system is turned off, a backup battery retains system parameters in the CMOS memory.

Each time the system is powered on, it is configured with these values, unless the CMOS has been corrupted or is faulty. The system Setup program is resident in the ROM BIOS (Read Only Memory Basic Input/Output System) so that it is available each time the computer is turned on. If, for some reason, the CMOS becomes corrupted, the system is configured with the default values stored in this ROM file.

As soon as the system is turned on, the power-on diagnostic routines check memory, attempt to prepare peripheral devices for action, and offer you the option of pressing to run Setup.

If certain non-fatal errors occur during the Power-On Self Test (POST) routines which are run when the system is turned on, you may be prompted to run Setup by pressing <F1>. See *BIOS Errors* earlier in this section for possible errors which may occur during the POST routines.

BIOS SETUP MENU

When you press <F1> in response to an error message received during the POST routines or when you press the key to enter the BIOS Setup Program, the following screen displays:

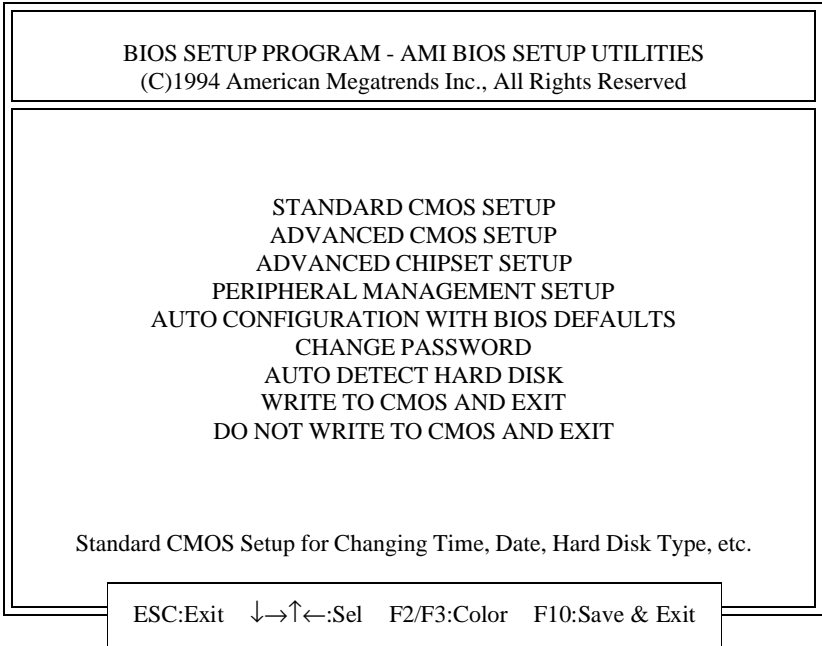

BIOS Setup Menu

NOTE: The BIOS Setup Menu and the options available for each selection on the menu may vary according to processor board. See individual processor board sections for more specific information.

Use the **Down Arrow** key to highlight the desired option and press <Enter>.

- Select **STANDARD CMOS SETUP** to make changes to the Standard CMOS Setup. The Setup program is described in the *Standard CMOS Setup* section of this manual. The following options may be changed:
 - Date and time
 - Hard disk type
 - Floppy drive type
 - Primary display
 - Keyboard

- Select **ADVANCED CMOS SETUP** to make changes to the Advanced CMOS Setup. The Setup program is described in the *Advanced Setup* section of this manual. The following options may be changed:
 - Above 1 MB Memory Test
 - Hit Message Display
 - Wait for <F1> If Any Error
 - System Boot Up Num Lock
 - Numeric Processor Test
 - Floppy Drive Seek at Boot
 - System Boot Up Sequence
 - External Cache Memory
 - Internal Cache Memory
 - Password Checking Option
 - Video ROM Shadow
 - Adaptor ROM Shadow
 - System ROM Shadow
 - Boot Sector Virus Protection

- Select **ADVANCED CHIPSET SETUP** to make changes to the Advanced Chip Set Setup. The Setup program is described in the *Advanced Setup* section of this manual. The following types of options are included in this selection, depending on requirements for the specific chip set used.
 - Bus Speed
 - DMA Speed
 - Memory Wait States

- Select **PERIPHERAL MANAGEMENT SETUP** to make changes to the Peripheral Management Setup. The Setup program is described in the *Peripheral Management Setup* section of this manual. The following options may be changed:
 - Programming Option
 - On-Board Floppy Drive
 - On-Board IDE Drive
 - First Serial Port Address
 - Second Serial Port Address
 - Parallel Port Address
 - Parallel Port Mode

- Select **AUTO CONFIGURATION WITH BIOS DEFAULTS** to load the BIOS Setup default values for the Advanced CMOS and Advanced Chip Set options. The BIOS Setup default values may be found on the Advanced CMOS and Advanced Chip Set Setup screens shown in the *Advanced Setup* section of this manual. After selecting this option, you remain at the BIOS Setup Menu screen. To save the BIOS Setup default values in CMOS memory, be sure to select **WRITE TO CMOS AND EXIT**.

- Select **CHANGE PASSWORD** to change the password required for access to the system or to the BIOS Setup programs. The procedure used to change the password is described later in this section.
- Select **AUTO DETECT HARD DISK** to have the BIOS automatically detect the type and parameters of each hard drive if you have IDE drive(s). This option is described later in this section.
- Select **WRITE TO CMOS AND EXIT** to *save* changes which have been made to the Setup screens or to the password, or if Auto Configuration with BIOS Defaults has been selected and you want to save the default values in CMOS memory. The system then continues the booting process.
- Select **DO NOT WRITE TO CMOS AND EXIT** to continue the booting process *without* saving any changes which have been made to the Setup screens or to the password, or if Auto Configuration with BIOS Defaults has been selected and you do *not* want to save the default values in CMOS memory.

The Setup Programs

When you select one of the Setup options on the BIOS Setup Menu, a warning message displays before any changes are allowed to any of the setup parameters.

BIOS SETUP PROGRAM - WARNING INFORMATION
(C)1994 American Megatrends Inc., All Rights Reserved

Improper Use of Setup may Cause Problems !!

If System Hangs, Reboot System and Enter Setup by Pressing the key

Do any of the following After Entering Setup

- (i) Alter Options to make System Work
- (ii) Load BIOS Setup Defaults
- (iii) Load Power-On Defaults

Hit <ESC> to Stop now, Any other Key to Continue

BIOS Setup Warning Message Screen

You have two options:

- Press <Esc> to return to the BIOS Setup Menu screen.
- Press any other key to continue with CMOS Setup. The Setup screen you selected displays.

The Setup programs are explained in the *Standard CMOS Setup*, *Advanced Setup* and *Peripheral Management Setup* sections of this manual.

Change Password

The Change Password option allows you to change the current password or to disable the password checking prompt by entering a null password.

The following window displays:

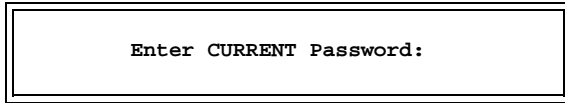

Enter CURRENT Password:

Type the current password and press <Enter>. The screen does not display the characters typed. If you type the incorrect password or press <Esc>, you return to the BIOS Setup Menu screen.

NOTE: The null password is the system default and is in effect if a password has not been assigned or if the CMOS has been corrupted. In this case, the "Enter CURRENT Password" prompt is bypassed.

After the current password has been correctly entered, the following window displays:



Enter NEW Password:

Type the new password and press <Enter>. The password cannot exceed six (6) characters in length. The screen does not display the characters typed.

NOTE: To *disable* password checking so that the password prompt will not appear under any circumstances, create a null password by pressing <Enter> without typing in a new password. This returns you immediately to the BIOS Setup Menu screen. To save the null password in CMOS memory, be sure to select **WRITE TO CMOS AND EXIT**.

After you have entered the new password, the following window displays:

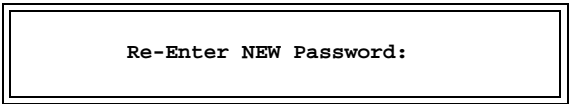

Re-key the new password and press <Enter>.

If the password confirmation is miskeyed, the following screen displays:

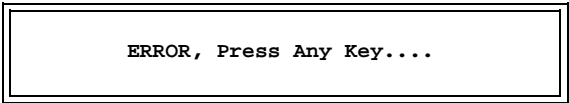

When you press any key, the screen clears and reissues the "Enter NEW Password:" prompt.

If the password confirmation is entered correctly, the following screen displays:

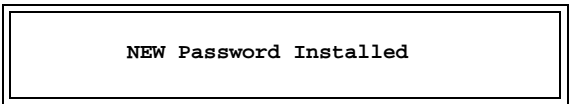

Press <Esc> to return to the BIOS Setup Menu screen. This screen allows you to save the change you have just made or exit from Setup

without saving the new password. To *save* the new password in CMOS memory, be sure to select **WRITE TO CMOS AND EXIT**.

Auto Detect Hard Disk

The Auto Detect Hard Disk option allows you to have the BIOS automatically detect the type of hard disk drive(s) in your system. The automatic detection functions only if you have IDE drives.

The following window displays:

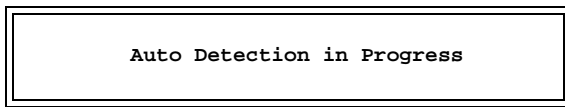

The auto detection is performed first for Hard Disk C:. The BIOS searches for the hard disk, and if it can access the drive it reads the disk parameters. It then searches the BIOS drive table for matching parameters to determine the disk type and displays both the disk type and parameters on the screen as shown below. If no matching parameters are found, the BIOS specifies the type as "47=USER TYPE." If it cannot access the drive, the BIOS times out and specifies the type as "Not Detected."

The screen displays the parameters for the disk drive and asks if you accept the values. After you accept or reject the parameters for Hard Disk C: as explained below, the BIOS performs the auto detection for Hard Disk D:.

NOTE: The auto detect feature displays disk parameter values as established by the drive manufacturer. If the drive has been formatted using any other values, accepting the auto detect values will cause erratic behavior. You must either reformat the drive to meet the manufacturer's specifications or use Standard CMOS Setup to enter parameters which match the current format of the drive.

BIOS SETUP PROGRAM - AUTO DETECT HARD DISK
(C)1994 American Megatrends Inc., All Rights Reserved

Cyln Head WPcom LZone Sect Size (MB)
Hard Disk C: Type : 47=USER TYPE 683 16 65535 683 38 203

Accept Parameters for C: (Y/N) ? N

You have two options for each disk drive:

- Press 'N' and <Enter> if you do not want to accept the hard disk type and its associated parameters or if it is "Not Detected." You may use Standard CMOS Setup to set up the correct parameters for the drive.
- Press 'Y' and <Enter> to accept the hard disk type and its associated parameters. These disk type values will be displayed when you view the Standard CMOS Setup screen. To save the hard disk parameter values in CMOS memory, be sure to select **WRITE TO CMOS AND EXIT** when you return to the BIOS Setup Menu screen.

Write to CMOS and Exit

The features selected and configured in the Setup screens are stored in the CMOS when this option is selected. The password is saved, and if Auto Configuration with BIOS Defaults has been selected, the defaults are saved. The CMOS checksum is calculated and written to the CMOS. Control is then passed back to the BIOS.

The following window displays:

```
Write to CMOS and Exit (Y/N) ? N
```

You have two options:

- Press 'N' and <Enter> to return to the Main Menu.
- Press 'Y' and <Enter> to *save* the system parameters and continue with the booting process.

Do Not Write to CMOS and Exit

This option passes control back to the BIOS *without* writing any changes to the CMOS.

The following window displays:

```
Want to Quit Without Saving (Y/N) ? N
```

You have two options:

- Press 'N' and <Enter> to return to the Main Menu.
- Press 'Y' and <Enter> to continue with the booting process *without* saving any system parameters.

KEY CONVENTIONS

Listed below is an explanation of the keys displayed at the bottom of the screens accessed through the System BIOS Setup program:

Key	Task
<Esc>	Exit to the BIOS Setup Menu.
Arrow keys	Move the cursor to the desired selection.
<Pg Up> <PgDn>, Ctrl/<PgUp> Ctrl/<PgDn>	Modify the default value of the options for the highlighted feature. If there are fewer than 10 available options, the Ctrl/<PgUp> and Ctrl/<PgDn> keys function the same as the <PgUp> and <PgDn> keys.
<F1>	Display help screen for the selected feature.
<F2>/<F3>	Change background and foreground colors.
<F5>	Retrieve the values which were resident when the current setup session was started. These values will be CMOS values if the CMOS was uncorrupted at the start of the session, or they will be the BIOS Setup default values.
<F6>	Load all features in the Advanced CMOS Setup, Advanced Chip Set Setup or Peripheral Management Setup with the BIOS Setup defaults.
<F7>	Load all features in the Advanced CMOS Setup, Advanced Chip Set Setup or Peripheral Management Setup with the Power-On defaults.
<F10>	Save all changes made to Setup and exits the program.
<p>NOTE: The default value for the prompts which occur when the <F5>, <F6> and <F7> keys are pressed is always <u>N</u> (No). Actually executing these options requires changing the <u>N</u> to <u>Y</u> (Yes) and pressing <Enter>.</p>	

STANDARD CMOS SETUP

When you enter Standard CMOS Setup, the following Setup screen appears:

AMIBIOS SETUP PROGRAM - STANDARD CMOS SETUP	
(C)1994 American Megatrends Inc., All Rights Reserved	
Date (mn/date/year)	: Thu, Feb 10 1994
Time (hour/min/sec)	: 15 : 23 : 15
	Base memory size : 640 KB
	Ext. memory size : 384 KB
	Cyln Head WPcom LZone Sect Size
Hard disk C: type	: 47 = USER TYPE 1224 16 1224 1224 36 330MB
Hard disk D: type	: 40 820 6 820 820 17 41MB
Floppy drive A:	: 1.44 MB, 3 1/2"
Floppy drive B:	: 1.2 MB, 5 1/4"
Primary display	: VGA/PGA/EGA
Keyboard	: Installed
	Calendar
<div style="border: 1px solid black; padding: 5px; width: fit-content;"> Month : Jan, Feb,.....Dec Date : 01, 02, 03,....31 Year : 1901, 1902,....2099 </div>	
<div style="border: 1px solid black; padding: 5px; width: fit-content;"> ESC:Exit ↓→↑←:Select F2/F3:Color PU/PD:Modify </div>	

The Standard CMOS Setup Screen

When you display the Standard CMOS Setup screen, the format is similar to the sample shown above. If values display for all parameters, the Setup parameters have been defined previously.

Setup detects and displays the Base memory and Extended memory size values; these parameters cannot be reset by the user.

NOTE: The values in this screen do not necessarily reflect the values appropriate for your processor board. Refer to the explanations below for specific instructions about entering correct information.

STANDARD CMOS OPTIONS

The descriptions for the system options listed below show the values as they appear if you have not run the Standard CMOS Setup program yet. Once values have been defined, they display each time Standard CMOS Setup is run.

Date

The Setup screen displays the system option:

Date (mn/date/year) : Tue, Jan 01, 1980

The Help window displays allowable settings:

Month : Jan, Feb, Dec
Date : 01, 02, 03,31
Year : 1901, 1902,....2099

There are three fields for entering the date. Use the left and right arrow keys to move from one field to another. As you scroll through the month, date or year field, the day of the week changes automatically to reflect the new date.

Time

The Setup screen displays the system option:

Time (hour/min/sec) : 00 : 00 : 00

The Help window displays:

Time is 24 hour format:-
Hour:(00-23), Minute:(00-59), Second:(00-59)
(1:30 AM = 01:30:00), (1:30 PM = 13:30:00)

There are three fields for entering the time. Use the left and right arrow keys to move from one field to another.

Hard Disk C: Type/Hard Disk D: Type

The Setup screen displays the system option:

Hard disk C: type : Not Installed

or

Hard disk D: type : Not Installed

The Help window displays:

FIXED type = 01...46, USER defined type = 47,
For type 47 Enter: Cyln, Head, WPcom, LZone, Sec,
(WPcom is 0 for ALL, 65535 for NONE)

The Cyln, Head, WPcom, LZone, Sect and Size display as you scroll through the disk types. Available drive types are listed at the end of this section.

Not Installed is also available for use as an option. This option could be used for diskless work stations and SCSI hard disks.

NOTE: If you have IDE drive(s), the BIOS can automatically detect the disk type and parameters of each hard drive. This feature is explained in the *Running the CMOS Setup Programs* section of this manual.

To enter disk type parameters which are not preprogrammed, scroll to type **47**, which places the cursor at the Cyln entry. You can then enter manually the Cyln, Head, WPcom, LZone and Sect parameters. Type the correct value in each field and press **<Enter>**. The size is automatically calculated and entered by the system based on the other parameters entered.

The parameters for type 47 under Hard disk C: and Hard disk D: may be different, which effectively allows two different user-definable hard disk types.

The following explains the headings which appear on the Standard CMOS Setup screen for the hard disk type entry:

Type is the numeric designation for a drive with certain identification parameters.

Cyln is the number of disk cylinders found in the specified drive type.

Head is the number of disk heads found in the specified drive type.

WPcom is the read delay circuitry which takes into account the timing differences between the inner and outer edges of the surface of the disk platter. The WPcom number designates the starting cylinder of the signal.

LZone is the disk cylinder where the head lands. This number determines the cylinder location where the heads will normally park when the system is shut down.

Sect designates the number of disk sectors per track. Every track is normally divided into 17 sectors.

Size is the formatted capacity of the drive (in megabytes) based on the following formula:

$$\# \text{ of heads} \times \# \text{ of cylinders} \times 17 \text{ sects/cyln} \times 512 \text{ bytes/sect}$$

Floppy Drive A: Type/Floppy Drive B: Type

The Setup screen displays the system option:

Floppy drive A: : Not Installed

or

Floppy drive B: : Not Installed

The Help window displays:

Options:-

360 KB 5-1/4", 1.2 MB 5-1/4", 720 KB 3-1/2",
1.44 KB 3-1/2", 2.88 MB 3-1/2", Not Installed

The **Not Installed** option can be used for diskless work stations.

Primary Display

The Setup screen displays the system option:

Primary display : Not Installed

The Help window displays:

Options:-

Monochrome, Color 40x25,
VGA/PGA/EGA, Color 80x25, Not Installed

The **Not Installed** option can be used for network file servers.

Keyboard

The Setup screen displays the system option:

Keyboard : Not Installed

The Help window displays:

Options:-

Installed : Test keyboard
Not Installed : Do not test keyboard

Saving and Exiting

When you have entered all of the appropriate information into the Standard CMOS Setup screen, verify that it is correct.

Press <Esc> to return to the BIOS Setup Menu screen. This screen allows you to save the changes you have just made or exit from Setup without saving the changes.

USING A WORKSHEET FOR SETUP

Copy this worksheet to record the values needed for the initial CMOS Setup program. Keep a copy in case of backup battery failure. Consult your drive manual if you are unsure about any of these values.

Hard Disk C: Type _____					
** Cyln	Head	WPcom	LZone	Sect	
_____	_____	_____	_____	_____	
Hard Disk D: Type _____					
** Cyln	Head	WPcom	LZone	Sect	
_____	_____	_____	_____	_____	
Floppy Drive A: Type _____					
Floppy Drive B: Type _____					
Primary Display _____					
Keyboard _____					

** Values required only if Type = 47 (USER-defined type)

FIXED DRIVE TYPES

Default fixed drive types defined in the standard BIOS are as follows:

- Cyln = Cylinders per drive
- Head = Heads per drive
- WPcom = Write precompensation (0 = all; 65535 = none)
- LZ = Landing zone
- Sect = Nbr of sectors per cylinder
- Size = Total storage size (Megabytes)

Type	Cyln	Head	WPcom	LZ	Sect	Size
1	306	4	128	305	17	10
2	615	4	300	615	17	20
3	615	6	300	615	17	31
4	940	8	512	940	17	62
5	940	6	512	940	17	47
6	615	4	65535	615	17	20
7	462	8	256	511	17	31
8	733	5	65535	733	17	30
9	900	15	65535	901	17	112
10	820	3	65535	820	17	20
11	855	5	65535	855	17	35
12	855	7	65535	855	17	50
13	306	8	128	319	17	20
14	733	7	65535	733	17	43
15			----- Invalid -----			
16	612	4	0	663	17	20
17	977	5	300	977	17	41
18	977	7	65535	977	17	57
19	1024	7	512	1023	17	60
20	733	5	300	732	17	30
21	733	7	300	732	17	43
22	733	5	300	733	17	30
23	306	4	0	336	17	10
24	925	7	0	925	17	54
25	925	9	65535	925	17	69
26	754	7	754	754	17	44
27	754	11	65535	754	17	69
28	699	7	256	699	17	41
29	823	10	65535	823	17	68
30	918	7	918	918	17	53
31	1024	11	65535	1024	17	94
32	1024	15	65535	1024	17	128
33	1024	5	1024	1024	17	43
34	612	2	128	612	17	10
35	1024	9	65535	1024	17	77

FIXED DRIVE TYPES (continued)

Type	Cyln	Head	WPcom	LZ	Sect	Size
36	1024	8	512	1024	17	68
37	615	8	128	615	17	41
38	987	3	987	987	17	25
39	987	7	987	987	17	57
40	820	6	820	820	17	41
41	977	5	977	977	17	41
42	981	5	981	981	17	41
43	830	7	512	830	17	48
44	830	10	65535	830	17	69
45	917	15	65535	918	17	114
46	1224	15	65535	1223	17	152
47			----- USER TYPE -----			

This page intentionally left blank.

ADVANCED SETUP

This section includes information on the operation of the Advanced CMOS Setup and Advanced Chip Set Setup screens of the BIOS. The information for these screens is segmented into individual sections for each processor board.

ADVANCED CMOS SETUP SCREEN

NOTE: The options on the Advanced CMOS Setup screens are entirely chip set specific. The screens and options vary with the chip set used on the particular processor board. Refer to the appropriate section for your processor board for more information. Typical selections for these screens are shown below.

- Above 1 MB Memory Test
- Hit Message Display
- Wait for <F1> If Any Error
- System Boot Up Num Lock
- Numeric Processor Test
- Floppy Drive Seek at Boot
- System Boot Up Sequence
- External Cache Memory
- Internal Cache Memory
- Password Checking Option
- Video ROM Shadow
- Adaptor ROM Shadow
- System ROM Shadow
- Boot Sector Virus Protection

ADVANCED CHIP SET SETUP SCREEN

NOTE: The options on the Advanced Chip Set Setup screens are entirely chip set specific. The screens and options vary with the chip set used on the particular processor board. Refer to the appropriate section for your processor board for more information. The following types of options are included in this selection, depending on requirements for the specific chip set used.

- Bus Speed
- DMA Speed
- Memory Wait States

ADVANCED CMOS SETUP - SB486T2C/66, SB486TC/50, SB486TC/33 and SB486SXTC/33

When you enter Advanced CMOS Setup, the following Setup screen appears:

BIOS SETUP PROGRAM - ADVANCED CMOS SETUP (C)1992 American Megatrends Inc., All Rights Reserved		
Above 1 MB Memory Test : Enable Hit Message Display : Enable Wait For <F1> If Any Error : Enable System Boot Up Num Lock : On Numeric Processor Test : Enable Floppy Drive Seek at Boot : Disable System Boot Up Sequence : C, A External Cache Memory : Enable Internal Cache Memory : Enable Password Checking Option : Setup Video ROM Shadow C000,16K : Enable Video ROM Shadow C400,16K : Enable Adaptor ROM Shadow C800,16K : Disable Adaptor ROM Shadow CC00,16K : Disable Adaptor ROM Shadow D000,16K : Disable Adaptor ROM Shadow D400,16K : Disable Adaptor ROM Shadow D800,16K : Disable Adaptor ROM Shadow DC00,16K : Disable	Adaptor ROM Shadow E000,16K : Disable Adaptor ROM Shadow E400,16K : Disable Adaptor ROM Shadow E800,16K : Disable Adaptor ROM Shadow EC00,16K : Disable System ROM Shadow F000,64K : Enable Boot Sector Virus Protection : Disable	
ESC:Exit ↓→↑←:Sel (Ctrl)Pu/Pd:Modify F1:Help F2/F3:Color F5:Old Values F6:BIOS Setup Defaults F7:Power-On Defaults		

The Advanced CMOS Setup Screen

When you display the Advanced CMOS Setup screen, the format is similar to the sample shown above. If values display for all parameters, the Setup parameters have been defined previously.

NOTE: The values in this screen do not necessarily reflect the values appropriate for your processor board. Refer to the explanations below for specific instructions about entering correct information.

ADVANCED CMOS OPTIONS

The descriptions for the system options listed below show the values as they appear if you have not run the Advanced CMOS Setup program yet. Once values have been defined, they display each time Advanced CMOS Setup is run.

The Advanced CMOS Setup program is equipped with a series of help screens which are accessed by pressing the <F1> key. Each help screen displays the options available for a particular configuration feature and provides special help for some of the options.

Above 1 MB Memory Test

This option, when enabled, executes the POST memory routines on the RAM above 1MB, if present on the system. If the option is disabled, the BIOS checks only the first 1MB of RAM.

The Setup screen displays the system option:

Above 1MB Memory Test : Enabled

Available options are:

Disabled
Enabled

Hit Message Display

The "Hit , If you want to run SETUP" message displays when the system boots up. Disabling this option prevents the message from displaying.

The Setup screen displays the system option:

Hit Message Display : Enabled

Available options are:

Disabled
Enabled

Wait For <F1> If Any Error

Before the system boots up, the BIOS executes the Power-On Self Test (POST) routines, a series of system diagnostic routines. If any of these tests fail but the system can still function, a non-fatal error has occurred. The BIOS responds with an appropriate error message followed by:

Press <F1> to RESUME

If this option is disabled, a non-fatal error does not generate the "Press <F1>" message, but the BIOS still displays the appropriate error message. This eliminates the need for any user response to a non-fatal error condition message. Non-fatal error messages are listed in *Appendix A - BIOS Messages*.

The Setup screen displays the system option:

Wait For <F1> If Any Error : Enabled

Available options are:

Disabled
Enabled

System Boot Up Num Lock

This option enables you to turn off the Num Lock option on the enhanced keyboard when the system is powered on. If the Num Lock is turned off, the arrow keys on the numeric keypad can be used, as well as the other set of arrow keys on the enhanced keyboard. The BIOS defaults to turning the Num Lock on.

The Setup screen displays the system option:

System Boot Up Num Lock : On

Available options are:

On
Off

Numeric Processor Test

This option indicates whether or not the system should test for the presence of the numeric processor.

The Setup screen displays the system option:

Numeric Processor Test : Enabled

Available options are:

Disabled
Enabled

Floppy Drive Seek at Boot

This option causes the system to have the floppy drive(s) seek during bootup. The default for this option is **Disabled** to allow a fast boot and to decrease the possibility of damage to the heads.

The Setup screen displays the system option:

Floppy Drive Seek at Boot : Disabled

Available options are:

Disabled
Enabled

System Boot Up Sequence

This option specifies the disk drive sequence the BIOS uses to search for a bootable device. The BIOS normally attempts to boot from hard disk C:, if present. If it is unsuccessful, it then attempts to boot from floppy drive A:. This option allows you to reverse the boot up sequence.

The Setup screen displays the system option:

System Boot Up Sequence : C:, A:

The Help window displays:

Available Options are :-

C:, A:

A:, C:

Press any key to continue

Specifying the standard DOS drive, typically C:, first speeds up the bootup process.

For example, if you have hard drive C: and floppy drive A:,

- Select **C:, A:** to seek hard drive C: first, then floppy drive A:. This option speeds up the bootup process.
- Select **A:, C:** to seek floppy drive A: first, then hard drive C:.

External Cache Memory

The external cache memory of the processor may be enabled or disabled using this option.

The Setup screen displays the system option:

External Cache Memory : Enabled

Available options are:

Disabled

Enabled

Internal Cache Memory

The internal cache memory of the CPU may be enabled or disabled using this option.

The Setup screen displays the system option:

Internal Cache Memory : Enabled

Available options are:

Disabled
Enabled

Password Checking Option

This option determines when a password is required for access to the system.

The Setup screen displays the system option:

Password Checking Option : Setup

Two options are available:

- Select **Setup** to have the password prompt appear only when an attempt is made to enter the System BIOS Setup program.
- Select **Always** to have the password prompt appear each time the system is powered on.

NOTE: To *disable* password checking, a null password should be entered in the Change Password function of the BIOS Setup Menu. (See the *Running the CMOS Setup Programs* section of this manual.) The null password is the system default and is in effect if a password has not been assigned or if the CMOS is corrupted.

Video or Adaptor ROM Shadow

ROM shadow is a technique in which BIOS code is copied from slower ROM to faster RAM. The BIOS is then executed from the RAM.

Each option allows for a segment of 16KB to be shadowed from ROM to RAM. If one of these options is enabled, and there is BIOS code present in that particular 16KB segment, the BIOS is shadowed.

Video ROM Shadow

Video BIOS shadowing may be done in 16KB increments at C000H and C400H. Enabling shadowing can speed up the operation of a machine because RAM can be accessed more rapidly than ROM and the data bus is wider to RAM.

The Setup screen displays the system option:

Video ROM Shadow XXXX,16K : Enabled

where XXXX is the base address of the 16KB segment of memory to be shadowed.

Available options are:

Disabled
Enabled

Adaptor ROM Shadow

Other ROM's may be shadowed in the memory area from C800H to F000H, depending upon preferences and system requirements.

The Setup screen displays the system option:

Adaptor ROM Shadow XXXX,16K : Disabled

where XXXX is the base address of the 16KB segment of memory to be shadowed.

Available options are:

Disabled
Enabled

System ROM Shadow

This option, if enabled, shadows the entire System BIOS (64KB in length).

The Setup screen displays the system option:

System ROM Shadow F000,64K : Enabled

Two options are available:

- Select **Enabled** for normal System BIOS shadow operation.
- Select **Disabled** to operate the System BIOS from ROM.

Boot Sector Virus Protection

This option, if enabled, write protects the disk boot sector.

The Setup screen displays the system option:

Boot Sector Virus Protection : Disabled

Available options are:

Disabled
Enabled

Saving and Exiting

When you have entered all of the appropriate information into the Advanced CMOS Setup screen, verify that it is correct.

Press <Esc> to return to the BIOS Setup Menu screen. This screen allows you to save the changes you have just made or exit from Setup without saving the changes.

This page intentionally left blank.

ADVANCED CHIP SET SETUP

When you enter Advanced Chip Set Setup, the following Setup screen appears:

BIOS SETUP PROGRAM - ADVANCED CHIPSET SETUP (C)1992 American Megatrends Inc., All Rights Reserved	
Hidden Refresh	: Enabled
AT Cycle Wait State	: Disabled
AT Cycle Between I/O Cycles	: 6
AT BUS Clock Selection	: CLKI/4
Non-Cacheable Block-1 Size	: Disabled
Non-Cacheable Block-1 Base	: 0 KB
Non-Cacheable Block-2 Size	: Disabled
Non-Cacheable Block-2 Base	: 0 KB
Video BIOS Area Cacheable	: Yes
<div style="display: flex; justify-content: space-between; padding: 5px;"> ESC:Exit ↓→↑←:Sel (Ctrl)Pu/Pd:Modify F1:Help F2/F3:Color </div> <div style="display: flex; justify-content: space-between; padding: 5px;"> F5:Old Values F6:BIOS Setup Defaults F7:Power-On Defaults </div>	

The Advanced Chip Set Setup Screen

When you display the Advanced Chip Set Setup screen, the format is similar to the sample shown above. If values display for all parameters, the Setup parameters have been defined previously.

NOTE: The values in this screen do not necessarily reflect the values appropriate for your processor board. Refer to the explanations below for specific instructions about entering correct information.

ADVANCED CHIP SET OPTIONS

The descriptions for the system options listed below show the values as they appear if you have not run the Advanced Chip Set Setup program yet. Once values have been defined, they display each time Advanced Chip Set Setup is run.

The Advanced Chip Set Setup program is equipped with a series of help screens which are accessed by pressing the <F1> key. Each help screen displays the options available for a particular configuration feature and provides special help for some of the options.

NOTE: Do *not* change the values for the options on this screen unless you understand the impact on system operation. Depending on your system configuration, selection of other values may cause unreliable system operation.

Hidden Refresh

This option allows the hidden refresh feature of the chip set to be disabled. Some option cards may not operate properly with hidden refresh enabled. For these cards, this feature should be set to **Disabled**.

The Setup screen displays the system option:

Hidden Refresh : Enabled

Available options are:

Disabled
Enabled

AT Cycle Wait State

This option allows you to insert one Wait State in the standard AT Bus cycle. For reliable operation, it may be necessary to enable this option if a Bus speed higher than the default is used.

The Setup screen displays the system option:

AT Cycle Wait State : Disabled

Available options are:

Disabled
Enabled

AT Cycle Between I/O Cycles

This option allows you to select the number of AT Bus clock cycles between Bus I/O cycles. Bus performance may be increased in some systems by selecting **2** in this option.

The Setup screen displays the system option:

AT Cycle Between I/O Cycles : 6

Available options are:

6
2

AT BUS Clock Selection

This option allows you to select the source of the AT Bus clock. The actual frequency of the Bus clock is developed by dividing the frequency of the selected clock (CLKI or CLK2I) by the divisor specified in the selection. Clock frequencies are as follows:

<u>Processor</u>	<u>Default</u>	<u>CLKI Frequency</u>	<u>CLK2I Frequency</u>
66MHz 486DX2	CLKI/4	33MHz	66MHz
50MHz 486DX	CLKI/6	50MHz	50MHz
33MHz 486DX	CLKI/4	33MHz	66MHz
33MHz 486SX	CLKI/4	33MHz	66MHz

The Setup screen displays the system option:

AT BUS Clock Selection : CLKI/X

where X is the divisor by which the clock is divided. The default divisor varies depending on your processor board, as noted above.

Available options are:

CLKI/6
CLKI/4
CLKI/3
CLK2I/5

Non-Cacheable Blocks

Two non-cacheable blocks may be configured in system memory. These blocks are typically used to prevent cacheing an area of memory which is mapped to an option card. There is a pair of registers for each non-cacheable block. The first register specifies the size of the non-cacheable block, which may be disabled or set to 64KB, 128KB, 256KB or 512KB. The second register is the base address, which can be set in increments of the block size selected in the first register in the pair.

The Setup screen displays the system options:

Non-Cacheable Block-X Size : Disabled
Non-Cacheable Block-X Base : 0 KB

where X is the number of the non-cacheable block.

Available options for block size are:

Disabled
64 KB
128 KB
256 KB
512 KB

Video BIOS Area Cacheable

This option allows caching of the video BIOS area of memory. The option is valid only if the video BIOS is shadowed.

The Setup screen displays the system option:

Video BIOS Area Cache : Yes

Available options are:

Yes

No

Saving and Exiting

When you have entered all of the appropriate information into the Advanced Chip Set Setup screen, verify that it is correct.

Press <Esc> to return to the BIOS Setup Menu screen. This screen allows you to save the changes you have just made or exit from Setup without saving the changes.

This page intentionally left blank.

ADVANCED CMOS SETUP - SB386SX/25

When you enter Advanced CMOS Setup, the following Setup screen appears:

BIOS SETUP PROGRAM - ADVANCED CMOS SETUP (C)1990 American Megatrends Inc., All Rights Reserved																															
<table style="width: 100%; border-collapse: collapse;"> <tr><td style="padding: 2px;">Above 1 MB Memory Test</td><td style="padding: 2px;">:Disable</td></tr> <tr><td style="padding: 2px;">Hit Message Display</td><td style="padding: 2px;">:Enable</td></tr> <tr><td style="padding: 2px;">Wait For <F1> If Any Error</td><td style="padding: 2px;">:Enable</td></tr> <tr><td style="padding: 2px;">System Boot Up Num Lock</td><td style="padding: 2px;">:On</td></tr> <tr><td style="padding: 2px;">Numeric Processor Test</td><td style="padding: 2px;">:Enable</td></tr> <tr><td style="padding: 2px;">Floppy Drive Seek At Boot</td><td style="padding: 2px;">:Disable</td></tr> <tr><td style="padding: 2px;">System Boot Up Sequence</td><td style="padding: 2px;">:C:, A:</td></tr> <tr><td style="padding: 2px;">Password Checking Option</td><td style="padding: 2px;">:Setup</td></tr> <tr><td style="padding: 2px;">Video ROM Shadow C000,32K</td><td style="padding: 2px;">:Enable</td></tr> <tr><td style="padding: 2px;">Adaptor ROM Shadow C800,32K</td><td style="padding: 2px;">:Disable</td></tr> <tr><td style="padding: 2px;">Adaptor ROM Shadow D000,32K</td><td style="padding: 2px;">:Disable</td></tr> <tr><td style="padding: 2px;">Adaptor ROM Shadow D800,32K</td><td style="padding: 2px;">:Disable</td></tr> <tr><td style="padding: 2px;">Adaptor ROM Shadow E000,32K</td><td style="padding: 2px;">:Disable</td></tr> <tr><td style="padding: 2px;">Adaptor ROM Shadow E800,32K</td><td style="padding: 2px;">:Disable</td></tr> <tr><td style="padding: 2px;">System ROM Shadow F000,64K</td><td style="padding: 2px;">:Enable</td></tr> </table>	Above 1 MB Memory Test	:Disable	Hit Message Display	:Enable	Wait For <F1> If Any Error	:Enable	System Boot Up Num Lock	:On	Numeric Processor Test	:Enable	Floppy Drive Seek At Boot	:Disable	System Boot Up Sequence	:C:, A:	Password Checking Option	:Setup	Video ROM Shadow C000,32K	:Enable	Adaptor ROM Shadow C800,32K	:Disable	Adaptor ROM Shadow D000,32K	:Disable	Adaptor ROM Shadow D800,32K	:Disable	Adaptor ROM Shadow E000,32K	:Disable	Adaptor ROM Shadow E800,32K	:Disable	System ROM Shadow F000,64K	:Enable	
Above 1 MB Memory Test	:Disable																														
Hit Message Display	:Enable																														
Wait For <F1> If Any Error	:Enable																														
System Boot Up Num Lock	:On																														
Numeric Processor Test	:Enable																														
Floppy Drive Seek At Boot	:Disable																														
System Boot Up Sequence	:C:, A:																														
Password Checking Option	:Setup																														
Video ROM Shadow C000,32K	:Enable																														
Adaptor ROM Shadow C800,32K	:Disable																														
Adaptor ROM Shadow D000,32K	:Disable																														
Adaptor ROM Shadow D800,32K	:Disable																														
Adaptor ROM Shadow E000,32K	:Disable																														
Adaptor ROM Shadow E800,32K	:Disable																														
System ROM Shadow F000,64K	:Enable																														
<table style="width: 100%; border-collapse: collapse;"> <tr> <td style="width: 10%; border: 1px solid black; height: 15px;"></td> <td style="padding: 2px;">ESC:Exit ↓→↑←:Sel (Ctrl)Pu/Pd:Modify F1:Help F2/F3:Color</td> <td style="width: 10%; border: 1px solid black; height: 15px;"></td> </tr> <tr> <td style="border: 1px solid black; height: 15px;"></td> <td style="padding: 2px;">F5:Old Values F6:BIOS Setup Defaults F7:Power-On Defaults</td> <td style="border: 1px solid black; height: 15px;"></td> </tr> </table>			ESC:Exit ↓→↑←:Sel (Ctrl)Pu/Pd:Modify F1:Help F2/F3:Color			F5:Old Values F6:BIOS Setup Defaults F7:Power-On Defaults																									
	ESC:Exit ↓→↑←:Sel (Ctrl)Pu/Pd:Modify F1:Help F2/F3:Color																														
	F5:Old Values F6:BIOS Setup Defaults F7:Power-On Defaults																														

The Advanced CMOS Setup Screen

When you display the Advanced CMOS Setup screen, the format is similar to the sample shown above. If values display for all parameters, the Setup parameters have been defined previously.

NOTE: The values in this screen do not necessarily reflect the values appropriate for your processor board. Refer to the explanations below for specific instructions about entering correct information

ADVANCED CMOS OPTIONS

The descriptions for the system options listed below show the values as they appear if you have not run the Advanced CMOS Setup program yet. Once values have been defined, they display each time Advanced CMOS Setup is run.

The Advanced CMOS Setup program is equipped with a series of help screens which are accessed by pressing the <F1> key. Each help screen displays the options available for a particular configuration feature and provides special help for some of the options.

Above 1 MB Memory Test

This option, when enabled, executes the POST memory routines on the RAM above 1MB, if present on the system. If the option is disabled, the BIOS checks only the first 1MB of RAM.

The Setup screen displays the system option:

Above 1MB Memory Test : Disabled

Available options are:

Disabled
Enabled

Hit Message Display

The "Hit , If you want to run SETUP" message displays when the system boots up. Disabling this option prevents the message from displaying.

The Setup screen displays the system option:

Hit Message Display : Enabled

Available options are:

Disabled
Enabled

Wait For <F1> If Any Error

Before the system boots up, the BIOS executes the Power-On Self Test (POST) routines, a series of system diagnostic routines. If any of these tests fail but the system can still function, a non-fatal error has occurred. The BIOS responds with an appropriate error message followed by:

Press <F1> to RESUME

If this option is disabled, a non-fatal error does not generate the "Press <F1>" message, but the BIOS still displays the appropriate error message. This eliminates the need for any user response to a non-fatal error condition message. Non-fatal error messages are listed in *Appendix A - BIOS Messages*.

The Setup screen displays the system option:

Wait For <F1> If Any Error : Enabled

Available options are:

Disabled
Enabled

System Boot Up Num Lock

This option enables you to turn off the Num Lock option on the enhanced keyboard when the system is powered on. If the Num Lock is turned off, the arrow keys on the numeric keypad can be used, as well as the other set of arrow keys on the enhanced keyboard. The BIOS defaults to turning the Num Lock on.

The Setup screen displays the system option:

System Boot Up Num Lock : On

Available options are:

On
Off

Numeric Processor Test

This option indicates whether or not the system should test for the presence of the numeric processor.

The Setup screen displays the system option:

Numeric Processor Test : Enabled

Available options are:

Disabled
Enabled

Floppy Drive Seek at Boot

This option causes the system to have the floppy drive(s) seek during bootup. The default for this option is **Disabled** to allow a fast boot and to decrease the possibility of damage to the heads.

The Setup screen displays the system option:

Floppy Drive Seek at Boot : Disabled

Available options are:

Disabled
Enabled

System Boot Up Sequence

This option specifies the disk drive sequence the BIOS uses to search for a bootable device. The BIOS normally attempts to boot from hard disk C:, if present. If it is unsuccessful, it then attempts to boot from floppy drive A:. This option allows you to reverse the boot up sequence.

The Setup screen displays the system option:

System Boot Up Sequence : C:, A:

The Help window displays:

Available Options are :-

C:, A:

A:, C:

Press any key to continue

Specifying the standard DOS drive, typically C:, first speeds up the bootup process.

For example, if you have hard drive C: and floppy drive A:,

- Select **C:, A:** to seek hard drive C: first, then floppy drive A:. This option speeds up the bootup process.
- Select **A:, C:** to seek floppy drive A: first, then hard drive C:.

Password Checking Option

This option determines when a password is required for access to the system.

The Setup screen displays the system option:

Password Checking Option : Setup

Two options are available:

- Select **Setup** to have the password prompt appear only when an attempt is made to enter the System BIOS Setup program.
- Select **Always** to have the password prompt appear each time the system is powered on.

NOTE: To *disable* password checking, a null password should be entered in the Change Password function of the BIOS Setup Menu. (See the *Running the CMOS Setup Programs* section of this manual.) The null password is the system default and is in effect if a password has not been assigned or if the CMOS is corrupted.

Video or Adaptor ROM Shadow

ROM shadow is a technique in which BIOS code is copied from slower ROM to faster RAM. The BIOS is then executed from the RAM.

Each option allows for a segment of 32KB to be shadowed from ROM to RAM. If one of these options is enabled, and there is BIOS code present in that particular 32KB segment, the BIOS will be shadowed.

Video ROM Shadow

Video BIOS shadowing may be done in a 32KB increment at C000H. Enabling shadowing can speed up the operation of a machine because RAM can be accessed more rapidly than ROM and the data bus is wider to RAM.

The Setup screen displays the system option:

Video ROM Shadow C000,32K : Enabled

where C000 is the base address of the 32KB segment of memory to be shadowed.

Available options are:

Disabled
Enabled

Adaptor ROM Shadow

Other ROM's may be shadowed in the memory area from C800H to F000H, depending upon preferences and system requirements.

The Setup screen displays the system option:

Adaptor ROM Shadow XXXX,32K : Disabled

where XXXX is the base address of the 32KB segment of memory to be shadowed.

Available options are:

Disabled
Enabled

System ROM Shadow

This option, if enabled, shadows the entire System BIOS (64KB in length).

The Setup screen displays the system option:

System ROM Shadow F000,64K : Enabled

Two options are available:

- Select **Enabled** for normal System BIOS shadow operation.
- Select **Disabled** if this area of RAM is not available for shadowing.

Saving and Exiting

When you have entered all of the appropriate information into the Advanced CMOS Setup screen, verify that it is correct.

Press <Esc> to return to the BIOS Setup Menu screen. This screen allows you to save the changes you have just made or exit from Setup without saving the changes.

ADVANCED CHIP SET SETUP

When you enter Advanced Chip Set Setup, the following Setup screen appears:

BIOS SETUP PROGRAM - ADVANCED CHIPSET SETUP (C)1990 American Megatrends Inc., All Rights Reserved	
Bus Clock Select	: PROCLK/6
DMA Clock Select	: BCLK/2
Additional RAM Wait State	: Enabled
<div style="display: flex; justify-content: space-between; align-items: center;"> <div style="border: 1px solid black; width: 20px; height: 20px;"></div> <div style="text-align: center;"> ESC:Exit ↓→↑←:Sel (Ctrl)Pu/Pd:Modify F1:Help F2/F3:Color F5:Old Values F6:BIOS Setup Defaults F7:Power-On Defaults </div> <div style="border: 1px solid black; width: 20px; height: 20px;"></div> </div>	

The Advanced Chip Set Setup Screen

When you display the Advanced Chip Set Setup screen, the format is similar to the sample shown above. If values display for all parameters, the Setup parameters have been defined previously.

NOTE: The values in this screen do not necessarily reflect the values appropriate for your processor board. Refer to the explanations below for specific instructions about entering correct information.

ADVANCED CHIP SET OPTIONS

The descriptions for the system options listed below show the values as they appear if you have not run the Advanced Chip Set Setup program yet. Once values have been defined, they display each time Advanced Chip Set Setup is run.

The Advanced Chip Set Setup program is equipped with a series of help screens which are accessed by pressing the <F1> key. Each help screen displays the options available for a particular configuration feature and provides special help for some of the options.

NOTE: Do *not* change the values for the options on this screen unless you understand the impact on system operation. Depending on your system configuration, selection of other values may cause unreliable system operation.

Bus Clock Select

This option selects the source of the ISA Bus Clock. The ISA Bus Clock is derived from the PROCLK (processor clock), which is twice the CPU speed.

The Setup screen displays the system option:

Bus Clock Select : PROCLK/6

Available options are:

/4

/5

/6

DMA Clock Select

This option allows you to program the DMA Clock to operate at either BCLK or BCLK/2 (Bus Clock). Operating at BCLK may cause erratic operation with some option boards.

The Setup screen displays the system option:

DMA Clock Select : BCLK/2

Available options are:

BCLK
BCLK/2

Additional RAM Wait State

This feature allows an additional wait state (T-state, two PROCLK cycles) to be inserted on all local memory accesses. The added wait state is inserted during the CAS active interval, extending the width of the CAS pulse.

This option must be set to **Enabled** if SIMM's slower than 60 ns. are used in a 25MHz processor board.

The Setup screen displays the system option:

Additional RAM Wait State : Enabled

Available options are:

Disabled
Enabled

Saving and Exiting

When you have entered all of the appropriate information into the Advanced Chip Set Setup screen, verify that it is correct.

Press <Esc> to return to the BIOS Setup Menu screen. This screen allows you to save the changes you have just made or exit from Setup without saving the changes.

PERIPHERAL MANAGEMENT SETUP

When you enter Peripheral Management Setup, the following Setup screen appears:

AMIBIOS SETUP PROGRAM - 341 SETUP	
(C)1994 American Megatrends Inc., All Rights Reserved	
Programming Option	: Auto
On-Board Floppy Drive	: Enabled
On-Board IDE Drive	: Enabled
First Serial Port Address	: 3F8H
Second Serial Port Address	: 2F8H
Parallel Port Address	: 3BCH
Parallel Port Mode	: Normal
<div style="display: flex; justify-content: space-between; padding: 5px;"> ESC:Exit ↓→↑←:Sel (Ctrl)Pu/Pd:Modify F1:Help F2/F3:Color </div> <div style="display: flex; justify-content: space-between; padding: 5px;"> F5:Old Values F6:BIOS Setup Defaults F7:Power-On Defaults </div>	

The Peripheral Management Setup Screen

When you display the Peripheral Management Setup screen, the format is similar to the sample shown above. If values display for all parameters, the Setup parameters have been defined previously.

NOTE: The values in this screen do not necessarily reflect the values appropriate for your processor board. Refer to the explanations below for specific instructions about entering correct information.

PERIPHERAL MANAGEMENT OPTIONS

The descriptions for the system options listed below show the values as they appear if you have not run the Peripheral Management Setup program yet. Once values have been defined, they display each time Peripheral Management Setup is run.

The Peripheral Management Setup program is equipped with a series of help screens which are accessed by pressing the <F1> key. Each help screen displays the options available for a particular configuration feature and provides special help for some of the options.

Programming Option

This option, when enabled, allows automatic or manual setup of on-board peripheral devices.

The Setup screen displays the system option:

Programming Option : Auto

Two options are available:

- Select **Auto** to have the BIOS configure the peripherals automatically as described below under *Automatic BIOS Configuration Features*.
- Select **Manual** to have the BIOS configure the peripherals as defined on the Peripheral Management screen. See the *Manual BIOS Configuration Features* section below.

NOTE: If **Auto** is selected, the BIOS disregards the values in the other screen options. The values for the other options may be changed, but the values determined by the Auto Configuration will be used.

Automatic BIOS Configuration Features

On-Board Floppy Controller

The BIOS attempts to enable any floppy controller on the ISA Bus. If no floppy controller is found on the ISA Bus, the on-board floppy controller is enabled.

On-Board IDE Interface

The BIOS attempts to enable any hard disk drive controller on the ISA bus. If no hard disk drive controller is found on the ISA bus, the on-board IDE Interface is enabled.

On-Board Serial Ports

The BIOS checks the ISA bus for serial ports. Any off-board serial ports found on the ISA bus are left at their assigned addresses. The First On-Board Serial Port (Serial Port 1) is configured with the first available address and the Second On-Board Serial Port (Serial Port 2) is configured with the next available address. The default address assignment order is 3F8H, 2F8H, 3E8H, 2E8H. Note that this same assignment order is used by the BIOS to place the active serial port addresses in lower memory (BIOS data area) for configuration as logical COM devices.

After all addresses have been assigned, any remaining on-board serial ports are disabled. On-Board Serial Port 1 utilizes interrupt 4 and Serial Port 2 utilizes interrupt 3.

For example, if there is one off-board serial port on the ISA bus and its address is set to 2F8H, the First On-Board Serial Port is assigned address 3F8H and the Second On-Board Serial Port is assigned address 3E8H. Configuration is then be as follows:

COM1 - First On-Board Serial Port (at 3F8H)
COM2 - off-board serial port (at 2F8H)
COM3 - Second On-Board Serial Port (at 3E8H)

On-Board Parallel Port

The BIOS checks the ISA bus for off-board parallel ports. Any parallel ports found on the ISA bus are left at their assigned addresses. The On-Board Parallel Port is automatically configured with the first available address not used by an off-board parallel port. The default address assignment order is 3BCH, 378H, 278H. Note that this same assignment order is used by the BIOS to place the active parallel port addresses in lower memory (BIOS data area) for configuration as logical LPT devices. The on-board Parallel Port utilizes interrupt 7.

Manual BIOS Configuration Features

On-Board Floppy Drive

The on-board floppy drive controller may be enabled or disabled using this option.

The Setup screen displays the system option:

On-Board Floppy Drive : Enabled

Available options are:

- Disabled
- Enabled

On-Board IDE Interface

The on-board IDE interface may be enabled or disabled using this option.

The Setup screen displays the system option:

On-Board IDE Drive : Enabled

Available options are:

- Disabled
- Enabled

First Serial Port Address

The address of the First On-Board Serial Port (Serial Port 1) may be set using this option.

The Setup screen displays the system option:

First Serial Port Address : 3F8H

Available options are:

3F8H
2F8H
3E8H
2E8H
Disabled

Second Serial Port Address

The address of the Second On-Board Serial Port (Serial Port 2) may be set using this option.

The Setup screen displays the system option:

Second Serial Port Address : 2F8H

Available options are:

3F8H
2F8H
3E8H
2E8H
Disabled

Parallel Port Address

The address of the On-Board Parallel Port may be set using this option.

The Setup screen displays the system option:

Parallel Port Address : 3BCH

Available options are:

3BCH
378H
278H
Disabled

Parallel Port Mode

This option allows configuration of the on-board parallel port in either the normal mode or the extended mode. Select **Extended** for bi-directional operation.

The Setup screen displays the system option:

Parallel Port Mode : Normal

Available options are:

Normal
Extended

Saving and Exiting

When you have entered all of the appropriate information into the Peripheral Management Setup screen, verify that it is correct.

Press <Esc> to return to the BIOS Setup Menu screen. This screen allows you to save the changes you have just made or exit from Setup without saving the changes.

APPENDIX A - BIOS MESSAGES

BIOS BEEP CODES

Errors may occur during the POST (Power-On Self Test) routines which are performed each time the system is powered on.

Non-fatal errors are those which, in most cases, allow the system to continue the bootup process. The error message normally appears on the screen. See *BIOS Error Messages* later in this section for descriptions of these messages.

Fatal errors are those which will not allow the system to continue the bootup procedure.

These fatal errors are usually communicated through a series of audible beeps. Each error message has its own specific beep code, defined by the number of beeps following the error detection. The following table lists the errors which are communicated audibly.

All errors listed, *with the exception of #8*, are fatal errors.

Beep Count	Message	Description
1	Refresh Failure	The memory refresh circuitry of the processor board is faulty.
2	Parity Error	A parity error was detected in the base memory (the first block of 64KB) of the system.
3	Base 64KB Memory Failure	A memory failure occurred within the first 64KB of memory.
4	Timer Not Operational	A memory failure occurred within the first 64KB of memory, or Timer #1 on the processor board has failed to function properly.
5	Processor Error	The CPU (Central Processing Unit) on the processor board has generated an error.
6	8042 - Gate A20 Failure	The keyboard controller (8042) contains the Gate A20 switch which allows the CPU to operate in protected mode. This error message means that the BIOS is not able to switch the CPU into protected mode.
7	Processor Exception Interrupt Error	The CPU on the processor board has generated an exception interrupt.

BIOS BEEP CODES (continued)

Beep Count	Message	Description
8	Display Memory Read/Write Error	The system video adaptor is either missing or its memory is faulty. NOTE: This is <i>not</i> a fatal error.
9	ROM Checksum Error	The ROM checksum value does not match the value encoded in the BIOS.
10	CMOS Shutdown Register Read/Write Error	The shutdown register for the CMOS memory has failed.
11	Cache Memory Bad; Do Not Enable Cache	The cache memory test failed. Cache memory is disabled. <i>Do <u>not</u> press <Ctrl><Alt><Shift><+> to enable cache memory.</i>

BIOS ERROR MESSAGES

If a non-fatal error occurs during the POST routines performed each time the system is powered on, the error message will appear on the screen in the following format:

ERROR Message Line 1
ERROR Message Line 2
Press <F1> to RESUME

Note the error message and press the <F1> key to continue with the bootup procedure.

NOTE: If the "Wait for <F1> If Any Error" option in the Advanced Setup portion of the BIOS Setup Program has been set to **Disabled**, the "Press <F1> to RESUME" prompt will not appear on the third line.

For most of the error messages, there is no ERROR Message Line 2. Generally, for those messages containing an ERROR Message Line 2, the text will be "RUN SETUP UTILITY." Pressing the <F1> key will invoke the BIOS Setup Program.

BIOS ERROR MESSAGES (continued)

A description of each error message appears below. The errors are listed in alphabetical order, not in the order in which they may occur.

Message	Description
8042 Gate-A20 Error	The gate-A20 portion of the keyboard controller (8042) has failed to operate correctly. Replace the 8042 chip.
Address Line Short!	An error has occurred in the address decoding circuitry of the processor board.
C: Drive Error	The BIOS is not receiving any response from hard disk drive C:. Check Standard CMOS Setup using the BIOS Setup Program to see if the correct hard disk drive has been selected.
C: Drive Failure	The BIOS cannot get <i>any</i> response from hard disk drive C:. It may be necessary to replace the hard disk.
Cache Memory Bad, Do Not Enable Cache!	Cache memory is defective.
CH-2 Timer Error	Most AT standard system boards include two timers. An error with Timer #1 is a fatal error, explained in <i>BIOS Beep Codes</i> earlier in this section. If an error occurs with Timer #2, this error message appears.
CMOS Battery State Low	There is a battery in the system which is used for storing the CMOS values. This battery appears to be low in power and needs to be replaced.
CMOS Checksum Failure	After the CMOS values are saved, a checksum value is generated to provide for error checking. If the previous value is different from the value currently read, this error message appears. To correct the error, run the BIOS Setup Program.
CMOS Display Type Mismatch	The type of video stored in CMOS does not match the type detected by the BIOS. Run the BIOS Setup Program to correct the error.
CMOS Memory Size Mismatch	If the BIOS finds the amount of memory on the system board to be different from the amount stored in CMOS, this error message is generated. Run the BIOS Setup Program to correct the error.
CMOS System Options Not Set	The values stored in the CMOS are either corrupt or nonexistent. Run the BIOS Setup Program to correct the error.

BIOS ERROR MESSAGES (continued)

Message	Description
CMOS Time & Date Not Set	Use Standard CMOS Setup in the BIOS Setup Program to set the date and time of the CMOS.
D: Drive Error	The BIOS is not receiving any response from hard disk drive D:. Check Standard CMOS Setup using the BIOS Setup Program to see if the correct hard disk drive has been selected.
D: Drive Failure	The BIOS cannot get <i>any</i> response from hard disk drive D:. It may be necessary to replace the hard disk.
Diskette Boot Failure	The disk used to boot up in floppy drive A: is corrupt, which means it cannot be used to boot up the system. Use another boot disk and follow the instructions on the screen.
Display Switch Not Proper	Some systems require that a video switch on the processor be set to either color or monochrome, depending upon the type of video being used. To correct this situation, set the switch properly after the system is powered off.
DMA Error	An error has occurred in the DMA controller on the processor board.
DMA #1 Error	An error has occurred in the first DMA channel on the processor board.
DMA #2 Error	An error has occurred in the second DMA channel on the processor board.
FDD Controller Failure	The BIOS is not able to communicate with the floppy disk drive controller. Check all appropriate connections after the system is powered off.
HDD Controller Failure	The BIOS is not able to communicate with the hard disk drive controller. Check all appropriate connections after the system is powered off.
INTR #1 Error	The interrupt channel #1 has failed the POST routine.
INTR #2 Error	The interrupt channel #2 has failed the POST routine.
Invalid Boot Diskette	The BIOS can read the disk in floppy drive A:, but it <i>cannot</i> boot up the system with it. Use another boot disk and follow the instructions on the screen.
KB/Interface Error	The BIOS has found an error with the keyboard connector on the processor board.

BIOS ERROR MESSAGES (continued)

Message	Description
Keyboard Error	The BIOS has encountered a timing problem with the keyboard. For the AMI Hi-Flex BIOS, the Keyboard option in the Standard CMOS Setup portion of the BIOS Setup Program may be set to Not Installed , which will cause the BIOS to skip the keyboard POST routines.
Keyboard Is Locked... Unlock It	The keyboard lock on the system is engaged. It must be unlocked to continue the bootup procedure.
No ROM BASIC	This error occurs when a proper bootable sector cannot be found on either floppy disk drive A: or hard disk drive C:. The BIOS will try at this point to run ROM Basic, and the error message is generated when the BIOS does not find it.
Off Board Parity Error	<p>The BIOS has encountered a parity error in memory installed on an adapter card in an I/O (Bus) expansion slot. The message appears as follows:</p> <p style="text-align: center;">OFF BOARD PARITY ERROR ADDR (HEX) = (XXXX)</p> <p>where XXXX is the address (in hexadecimal) at which the error has occurred. "Off Board" means that it is part of the memory installed via an expansion card in an I/O (Bus) slot, as opposed to memory attached directly to the processor board.</p>
On Board Parity Error	<p>The BIOS has encountered a parity error in memory installed on the processor board. The message appears as follows:</p> <p style="text-align: center;">ON BOARD PARITY ERROR ADDR (HEX) = (XXXX)</p> <p>where XXXX is the address (in hexadecimal) at which the error has occurred. "On Board" means that it is part of the memory attached directly to the processor board, as opposed to memory installed via an expansion card in an I/O (Bus) slot.</p>
Parity Error ????	The BIOS has encountered a parity error with some memory in the system, but it is not able to determine the address of the error.

ISA BIOS NMI HANDLER MESSAGES

ISA NMI messages are described below.

Message	Description
Memory Parity Error	Memory failed. The message appears as follows: MEMORY PARITY ERROR AT XXXXX where XXXXX is the address (in hexadecimal) at which the error has occurred. If the memory location cannot be determined, the message is "Memory Parity Error ????"
I/O Card Parity Error	An expansion card failed. The message appears as follows: I/O PARITY ERROR AT XXXXX where XXXXX is the address (in hexadecimal) at which the error has occurred. If the address cannot be determined, the message is "I/O Card Parity Error ????"
DMA Bus Time-Out	A device has driven the bus signal for more than 7.8 microseconds.

PORT 80 CODES

The following codes are presented on Port 80H as the BIOS performs its reset procedure.

Code	Description
01	Processor register test about to start and NMI to be disabled.
02	NMI disabled. Power-on delay starting.
03	Power-on delay completed. Any initialization before keyboard BAT in progress.
04	Any initialization before keyboard BAT completed. Reading keyboard SYS bit, to check soft reset/power-on.
05	Soft reset/power-on determined. Going to enable ROM, i.e. disable shadow RAM/Cache, if any.
06	ROM is enabled. Calculating ROM BIOS checksum, and waiting for keyboard controller input buffer to be free.
07	ROM BIOS checksum passed, keyboard controller input buffer free. Going to issue the BAT command to keyboard controller.
08	BAT command to keyboard controller issued. Going to verify the BAT command.
09	Keyboard controller BAT result verified. Keyboard command byte to be written next.
0A	Keyboard command byte code issued. Going to write command byte data.
0B	Keyboard controller command byte written. Going to issue Pin-23,24 blocking/unblocking command.
0C	Pin-23,24 of keyboard controller blocked/unblocked. NOP command of keyboard controller to be issued next.
0D	NOP command processing done. CMOS shutdown register test to be done next.
0E	CMOS shutdown register read/write test passed. Going to calculate CMOS checksum and update DIAG byte.
0F	CMOS checksum calculation done, DIAG byte written. CMOS initialization to start (If "INIT CMOS IN EVERY BOOT IS SET").
10	CMOS initialization done (if any). CMOS status register about to initialize for date and time.

PORT 80 CODES (continued)

Code	Description
11	CMOS status register initialized. Going to disable DMA and interrupt controllers.
12	DMA controller #1, #2, interrupt controller #1, #2 disabled. About to disable video display and initialize port-B.
13	Video display disabled and port-B initialized. Chipset initialization/auto memory detection about to start.
14	Chipset initialization/auto memory detection over. 8254 CH-2 timer test about to start.
15	CH-2 timer test halfway. 8254 CH-2 timer test to be completed.
16	CH-2 timer test over. 8254 CH-1 timer test to be completed.
17	CH-1 timer test over. 8254 CH-0 timer test to be completed.
18	CH-0 timer test over. About to start memory refresh.
19	Memory refresh started. Memory refresh test to be done next.
1A	Memory refresh line toggling. Going to check 15 microsecond ON/OFF time.
1B	Memory refresh period 30 microsecond test completed. Base 64KB memory test about to start.
20	Base 64KB memory test started. Address line test to be done next.
21	Address line test passed. Going to do toggle parity.
22	Toggle parity over. Going for sequential data read/write test.
23	Base 64KB sequential data read/write test passed. Any setup before interrupt vector initialization about to start.
24	Setup required before vector initialization completed. Interrupt vector initialization about to start.
25	Interrupt vector initialization done. Going to read I/O port of 8042 for turbo switch (if any).
26	I/O port of 8042 read. Going to initialize global data for turbo switch.
27	Global data initialization over. Any initialization after interrupt vector to be done next.
28	Initialization after interrupt vector completed. Going to monochrome mode setting.

PORT 80 CODES (continued)

Code	Description
29	Monochrome mode setting done. Going for color mode setting.
2A	Color mode setting done. About to go for toggle parity before optional ROM test.
2B	Toggle parity over. About to give control for any setup required before optional video ROM check.
2C	Processing before video ROM control done. About to look for optional video ROM and give control.
2D	Optional video ROM control done. About to give control to do any processing after video ROM returns control.
2E	Return from processing after video ROM control. If EGA/VGA not found, do display memory read/write test.
2F	EGA/VGA not found. Display memory read/write test about to start.
30	Display memory read/write test passed. About to look for the retrace checking.
31	Display memory read/write test or retrace checking failed. About to do alternate display memory read/write test.
32	Alternate display memory read/write test passed. About to look for alternate display retrace checking.
33	Video display checking over. Verification of display type with switch setting and actual card to start.
34	Verification of display adaptor done. Display mode to be set next.
35	Display mode set completed. BIOS ROM data area about to be checked.
36	BIOS ROM data area check over. Going to set cursor for power-on message.
37	Cursor setting for power-on message complete. Going to display power-on message.
38	Power-on message display complete. Going to read new cursor position.
39	New cursor position read and saved. Going to display reference string.
3A	Reference string display over. Going to display the "Hit " message.

PORT 80 CODES (continued)

Code	Description
3B	"Hit " message displayed. Virtual mode memory test about to start.
40	Preparation for virtual mode test started. Going to verify from video memory.
41	Returned after verifying from display memory. Going to prepare the descriptor tables.
42	Descriptor tables prepared. Going to enter in virtual mode for memory test.
43	Entered in virtual mode. Going to enable interrupts for diagnostics mode.
44	Interrupts enabled (if diagnostics switch is on). Going to initialize data to check memory remap at 0:0.
45	Data initialized. Going to check for memory remap at 0:0 and find total system memory size.
46	Memory remap test done. Memory size calculation over. About to go for writing patterns to test memory.
47	Pattern to be tested written in extended memory. Going to write patterns in base 64KB memory.
48	Patterns written in base 64KB memory. Going to find out amount of memory below 1MB memory.
49	Amount of memory below 1MB found and verified. Going to find out amount of memory above 1MB memory.
4A	Amount of memory above 1MB found and verified. Going for BIOS ROM data area check.
4B	BIOS ROM data area check over. Going to check and clear memory below 1MB for soft reset.
4C	Memory below 1MB cleared. (SOFT RESET) Going to clear memory above 1MB.
4D	Memory above 1MB cleared. (SOFT RESET) Going to save memory size.
4E	Memory test started. (NO SOFT RESET) About to display first 64KB memory test.
4F	Memory size display started. This will be updated during memory test. Going for sequential and random memory test.

PORT 80 CODES (continued)

Code	Description
50	Memory test below 1MB completed. Going to adjust memory size for relocation/shadow.
51	Memory size adjusted due to relocation/shadow. Memory test above 1MB to follow.
52	Memory test above 1MB completed. Going to prepare to go back to real mode.
53	CPU registers saved, including memory size. Going to enter in real mode.
54	Shutdown successful; CPU in real mode. Going to restore registers saved during preparation for shutdown.
55	Registers restored. Going to disable gate A20 address line.
56	A20 address line disable successful. BIOS ROM data area about to be checked.
57	BIOS ROM data area check halfway. BIOS ROM data area check to be completed.
58	BIOS ROM data area check over. Going to clear "Hit " message.
59	"Hit " message cleared. About to start DMA and interrupt controller test.
60	DMA page register test passed. About to verify from display memory.
61	Display memory verification over. About to go for DMA #1 base register test.
62	DMA #1 base register test passed. About to go for DMA #2 base register test.
63	DMA #2 base register test passed. About to go for BIOS ROM data area check.
64	BIOS ROM data area check halfway. BIOS ROM data area check to be completed.
65	BIOS ROM data area check over. About to program DMA unit 1 and 2.
66	DMA unit 1 and 2 programming over. About to initialize 8259 interrupt controller.
67	8259 initialization over. About to start keyboard test.
80	Keyboard test started. About to issue keyboard reset command.

PORT 80 CODES (continued)

Code	Description
81	Keyboard reset successful. About to check stuck key and issue interface test command (if any error).
82	Keyboard controller interface test over. About to write command byte and initialize circular buffer.
83	Command byte written; global data initialization done. About to check for lock-key.
84	Lock-key checking over. About to check for memory size mismatch with CMOS.
85	Memory size check done. About to display soft error and check for password or bypass setup.
86	Password checked. About to do programming before setup.
87	Programming before setup completed. Going to CMOS setup program.
88	Returned from CMOS setup program and screen cleared. About to do programming after setup.
89	Programming after setup completed. Going to display power-on screen message.
8A	First screen message displayed. About to display "Wait. . ." message, and do mouse check and initialization of mouse.
8B	"Wait. . ." message displayed; mouse check and initialization done. About to do main and video BIOS shadow.
8C	Main and video BIOS shadow successful. Setup options programming after CMOS setup about to start.
8D	Setup options are programmed. Going for hard disk, floppy reset.
8E	Hard disk, floppy reset applied. About to go for floppy check.
8F	Floppy check returns that floppy is to be initialized. Floppy setup to follow.
90	Floppy setup over. Test for hard disk presence to be done.
91	Hard disk presence test over. Hard disk setup to follow.
92	Hard disk setup complete. About to go for BIOS ROM data area check.
93	BIOS ROM data area check halfway. BIOS ROM data area check to be completed.

PORT 80 CODES (continued)

Code	Description
94	BIOS ROM data area check over. Going to set base and extended memory size.
95	Memory size adjusted due to mouse support, hard disk type 47. Going to verify from display memory.
96	Returned after verifying from display memory. Going to do any initialization before C800 optional ROM control.
97	Any initialization before C800 optional ROM control over. Optional ROM check and control to be done next.
98	Optional ROM control done. About to give control to do any required processing after optional ROM returns control.
99	Any initialization required after optional ROM test over. Going to set up timer data area and printer base address.
9A	Returned after setting timer and printer base address. Going to set RS-232 base address.
9B	Returned after setting RS-232 base address. Going to do any initialization before coprocessor test.
9C	Required initialization before coprocessor test over. Going to initialize coprocessor next.
9D	Coprocessor initialized. Going to do any initialization after coprocessor test.
9E	Initialization after coprocessor test completed. Going to check extended keyboard, keyboard ID and num-lock.
9F	Extended keyboard check done, ID flag set, num-lock on/off. Keyboard ID command to be issued.
A0	Keyboard ID command issued. Keyboard ID flag to be reset.
A1	Keyboard ID flag reset. Cache memory test to follow.
A2	Cache memory test over. Going to display any soft errors.
A3	Soft error display complete. Going to set keyboard typematic rate.
A4	Keyboard typematic rate set. Going to program memory wait states.
A5	Memory wait states programming over. Screen to be cleared next.
A6	Screen cleared. Going to enable parity and NMI.

PORT 80 CODES (continued)

Code	Description
A7	NMI and parity enabled. Going to do any initialization required before giving control to optional ROM at E000.
A8	Initialization before E000 ROM control over. E000 ROM to get control next.
A9	Returned from E000 ROM control. Going to do any initialization required after E000 optional ROM control.
AA	Initialization after E000 optional ROM control over. Going to display system configuration.
00	System configuration displayed. Going to give control to INT 19H boot loader.

BUG REPORT

While we have tried to assure this manual is error free, it is a fact of life that works of man have errors. We request you to detail any errors you find on this "BUG REPORT" and return it to us. We will correct the errors/problems and send you a new manual as soon as available. Please return to:



INDUSTRIAL COMPUTER SOURCE®

Attn: Documentation Department
P.O. Box 910557
San Diego, CA 92191-0557

Your Name: _____

Company Name: _____

Address: _____ M/S _____

Address: _____

City: _____ State: _____ Zip: _____

Phone: (_____) _____

Manual Revision: 8701027 Revision L

Please list the page numbers and errors found. Thank you!

This page intentionally left blank.