



INDUSTRIAL COMPUTER SOURCE[®]

Model RS422AT-P Product Manual

MANUAL NUMBER : 00650-008-35B



INDUSTRIAL COMPUTER SOURCE[®]



<http://www.indcompsrc.com>

6260 SEQUENCE DRIVE, SAN DIEGO, CA 92121-4371 (619) 677-0877 (FAX) 619-677-0895

INDUSTRIAL COMPUTER SOURCE EUROPE TEL (1) 69.18.74.40 FAX (1) 64.46.40.42 • INDUSTRIAL COMPUTER SOURCE (UK) LTD TEL 01243-533900 FAX 01243-532949

FOREWARD

This product manual provides information to install, operate and or program the referenced product(s) manufactured or distributed by Industrial Computer Source. The following pages contain information regarding the warranty and repair policies.

Technical assistance is available at: **1-800-480-0044**.

Manual Errors, Omissions and Bugs: A "Bug Sheet" is included as the last page of this manual. Please use the "Bug Sheet" if you experience any problems with the manual that requires correction.

NOTE

The information in this document is provided for *reference* only. Industrial Computer Source does not assume any liability arising out of the application or use of the information or products described herein. This document may contain or reference information and products protected by copyrights or patents and does not convey any license under the patent rights of Industrial Computer Source, nor the rights of others.

Copyright © 1995 by Industrial Computer Source, a California Corporation, 6260 Sequence Drive, San Diego, CA 92121-4371. Industrial Computer Source is a Registered Trademark of Industrial Computer Source. All trademarks and registered trademarks are the property of their respective owners. All rights reserved. Printed in the United States of America. No part of this publication may be reproduced, stored in a retrieval system, or transmitted, in any form or by any means, electronic, mechanical, photocopying, recording , or otherwise, without the prior written permission of the publisher.

This page intentionally left blank

Guarantee

A thirty day money-back guarantee is provided on all **standard** products sold. **Special order products** are covered by our Limited Warranty, *however they may not be returned for refund or credit. EPROMs, RAM, Flash EPROMs or other forms of solid electronic media are not returnable for credit - but for replacement only. Extended Warranty available. Consult factory.*

Refunds

In order to receive refund on a product purchase price, the product must not have been damaged by the customer or by the common carrier chosen by the customer to return the goods, and the product must be returned complete (meaning all manuals, software, cables, etc.) within 30 days of receipt and in as-new and resalable condition. The **Return Procedure** must be followed to assure prompt refund.

Restocking Charges

Product returned *after* 30 days, and *before* 90 days, of the purchase will be subject to a **minimum** 20% restocking charge and any charges for damaged or missing parts.

Products not returned within 90 days of purchase, or products which are not in as-new and resaleable condition, are not eligible for credit return and will be returned to the customer.

Limited Warranty

One year limited warranty on all products sold with the exception of the "Performance Series" I/O products, which are warranted to the original purchaser, for as long as they own the product, subject to all other conditions below, including those regarding neglect, misuse and acts of God. Within one year of purchase, Industrial Computer Source will repair or replace, at our option, any defective product. At any time after one year, we will repair or replace, at our option, any defective "Performance Series" I/O product sold. This does not include products damaged in shipment, or damaged through customer neglect or misuse. Industrial Computer Source will service the warranty for all standard catalog products for the first year from the date of shipment. After the first year, for products not manufactured by Industrial Computer Source, the remainder of the manufacturer's warranty, if any, will be serviced by the manufacturer directly.

The **Return Procedure** must be followed to assure repair or replacement. Industrial Computer Source will normally return your replacement or repaired item via UPS Blue. *Overnight delivery or delivery via other carriers is available at additional charge.*

The limited warranty is void if the product has been subjected to alteration, neglect, misuse, or abuse; if any repairs have been attempted by anyone other than Industrial Computer Source or its authorized agent; or if the failure is caused by accident, acts of God, or other causes beyond the control of Industrial Computer Source or the manufacturer. Neglect, misuse, and abuse shall include any installation, operation, or maintenance of the product other than in accordance with the owners' manual.

No agent, dealer, distributor, service company, or other party is authorized to change, modify, or extend the terms of this Limited Warranty in any manner whatsoever. Industrial Computer Source reserves the right to make changes or improvements in any product without incurring any obligation to similarly alter products previously purchased.



Shipments not in compliance with this Guarantee and Limited Warranty Return Policy will not be accepted by Industrial Computer Source.

Return Procedure

For any Limited Warranty or Guarantee return, please contact Industrial Computer Source's Customer Service at **1-800-480-0044** and obtain a Return Material Authorization (RMA) Number. All product(s) returned to Industrial Computer Source for service or credit **must** be accompanied by a Return Material Authorization (RMA) Number. Freight on all returned items **must** be prepaid by the customer who is responsible for any loss or damage caused by common carrier in transit. Returns for Warranty **must** include a Failure Report for each unit, by serial number(s), as well as a copy of the original invoice showing date of purchase.

To reduce risk of damage, returns of product must be in an Industrial Computer Source shipping container. If the original container has been lost or damaged, new shipping containers may be obtained from Industrial Computer Source Customer Service at a nominal cost.

Limitation of Liability

In no event shall Industrial Computer Source be liable for any defect in hardware or software or loss or inadequacy of data of any kind, or for any direct, indirect, incidental, or consequential damages in connection with or arising out of the performance or use of any product furnished hereunder. Industrial Computer Source liability shall in no event exceed the purchase price of the product purchased hereunder. The foregoing limitation of liability shall be equally applicable to any service provided by Industrial Computer Source or its authorized agent.

Some *Sales Items* and *Customized Systems* are **not** subject to the guarantee and limited warranty. However in these instances, any deviations will be disclosed prior to sales and noted in the original invoice. ***Industrial Computer Source reserves the right to refuse returns or credits on software or special order items.***

Table of Contents

| | |
|---|------------|
| FOREWARD | iii |
| Guarantee | v |
| Limited Warranty | v |
| Return Procedure | vi |
| Limitation of Liability | vi |
| | |
| Chapter 1: Installation | 1-1 |
| Backing up the Disk | 1-1 |
| Hard Disk Installation | 1-1 |
| Installing the Card | 1-2 |
| | |
| Chapter 2: Functional Description | 2-1 |
| How to remain CE Compliant | 2-2 |
| | |
| Chapter 3: Option Selection | 3-1 |
| | |
| Chapter 4: Address Selection | 4-1 |
| Standard Address Assignments for PC and PC/XT Computers | 4-1 |
| | |
| Chapter 5: Programming | 5-1 |
| Sample Programs | 5-1 |
| | |
| Chapter 6: Connector Pin Assignments | 6-1 |
| | |
| Chapter 7: Specifications | 7-1 |
| | |
| Appendix A: Application Considerations | A-1 |
| | |
| Year of CE Labelling: 1996 | 1 |

List of Figures

| | |
|--|-----|
| Figure 1: RS422AT-P Block Diagram | 2-2 |
| Figure 2: RS422AT-P Option Selection Map | 3-3 |

Current Revision 35B

September 1997

This page intentionally left blank

Chapter 1: Installation

Backing up the Disk

The software provided with the RS422AT-P card is on a 3.5" diskette. As with any software package, you should make backup copies for everyday use and place your original master diskette in a safe location.

The easiest way to make a backup copy is to use the DOS DISKCOPY utility.

In a single-drive system the command is DISKCOPY A:A:

In a two-drive system the command is DISKCOPY A: B: (This will copy the master disk in drive A to the backup disk in drive B.)

Hard Disk Installation

The files contained on the master diskette may also be copied onto your hard disk. To do this perform the following:

- 1.) Place the master diskette into a floppy drive.
- 2.) Change the active drive to the drive that has the master diskette installed. For example, if the diskette is the A drive, type A:
- 3.) Type INSTALL and follow the screen prompts.

Files contained on the disk are stored in separate directories as follows:

| | |
|-----------------|---|
| ROOT DIRECTORY: | Contains the FINDBASE PROGRAM that will help you to decide what base address to use with the card. Also contains the COM422ST.EXE setup and calibration program. |
| PSAMPLES: | Contains Pascal samples and the Pascal-linkable driver. |
| CSAMPLES: | Contains "C" samples and the "C"-linkable driver. |
| BSAMPLES: | Contains the BASIC and QuickBASIC samples as well as the binary and linkable drivers. |
| VBACCESS: | VisualBASIC utility driver that includes PEEK and POKE statements from reading and writing RAM as well as INPORT and OUTPORT for reading and writing I/O. The driver is in the form of a DLL and allows you to access hardware as if the language was designed for it when you use VisualBASIC for Windows. |

Installing the Card

The RS422AT-P card can be installed in either a long or short slot of an IBM PC/XT/AT or compatible computer. Before installing the card, carefully read the OPTION SELECTION and ADDRESS SELECTION sections of this manual and configure the card according to your requirements. Use the FINDBASE program provided on diskette with the card to select the base address for the card. Use the program called COM422ST to select other options.

Be especially careful with address selection. If the addresses of two installed functions overlap, you will experience unpredictable computer behavior.

To install the card:

1. Turn off computer power.
2. Remove the computer cover.
3. Remove the blank mounting bracket.
4. Install jumpers for selected options. See section 3.
5. Select the base address on the card. See section 4.
6. Install the card in an I/O expansion slot.
7. Install the I/O cable.
8. Inspect for proper fit of the card and cable and tighten screws.
9. Turn the computer ON and observe the LED indicators. The LED's will blink when there is any activity on the communication lines.
10. Turn the computer OFF and replace the computer cover.

Chapter 2: Functional Description

The RS422AT-P card was designed for industrial applications, and is economical to use. It is half size and can be installed in either short or long slots of IBM PC/XT/AT or compatible computers. The card can be used for either RS-422 serial communications or RS-485 communications. (The RS-485 specification allows multiple transmitters and receivers to communicate over a two-wire “party line” bus.) Type NS16450 UART’s are used as the Asynchronous Communication Element (ACE). Use of the same ACE as in IBM original equipment makes the card 100% compatible with existing programs when the card address is set as either COM-1 or COM-2.

However, use of the RS422AT-P card is not restricted to COM-1 or COM-2. Continuous address selection is available anywhere within the I/O address range 000 to 3FF hex.

A crystal oscillator is located on the card. This oscillator permits precise selection of baud rate from 50 to 56000.

The output transceiver used, the new generation type 75176, is capable of driving extremely long communication lines at high baud rates. It is capable of driving up to 60mA on balanced lines and receiving inputs as low as 200mV differential signal superimposed on common mode noise of maximum -7V/+12V. In case of communication conflict, the transceivers feature thermal shutdown. For increased noise immunity, the communication lines are loaded at the receiver and biased at the transmitter.

Two LED indicators are provided on the RS422AT-P card. The LED’s blink to indicate activity on the transmitting and receiving lines and are useful for problem diagnosis.

In addition to dual, differential Transmit and Receive lines, single-ended buffered RTS and CTS lines are provided on the output connector. The RTS line can be used to control the Transmitter and Receiver. The CTS line is normally controlled by software. If you are not controlling CTS under software, CTS must be pulled up to +5VDC for the card to operate. This is easily done by installing a jumper at a jumper position labelled CTS. If you prefer, you can omit that jumper and install a jumper in the mating connector between pins 5 & 9. When that jumper is installed, it serves to check for proper installation of the communication cable. To check for proper cable connection, you can read the CTS bit by software.

Full Duplex, Half Duplex, or Simplex configuration can be selected by jumper options.

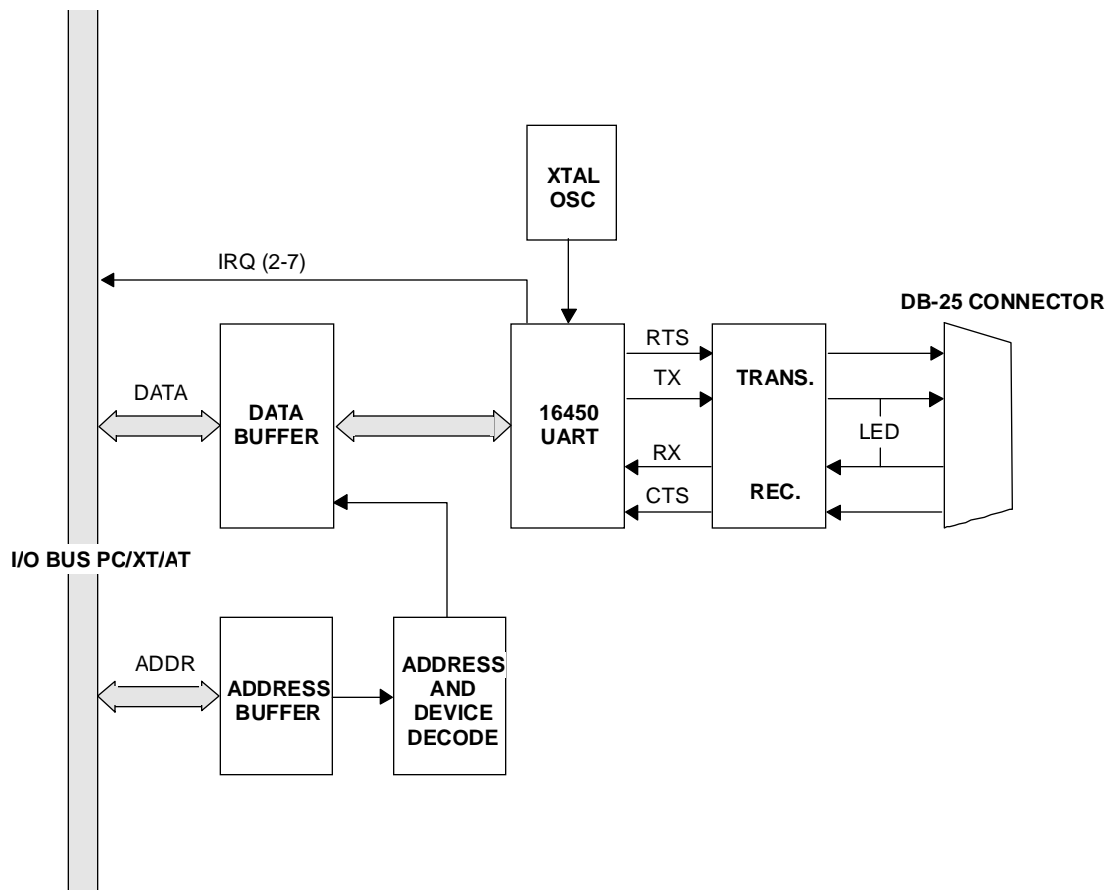

Figure 1: RS422AT-P Block Diagram

How to remain CE Compliant

In order for machines to remain CE compliant, only CE compliant parts may be used. To keep a chassis compliant it must contain only compliant cards, and for cards to remain compliant they must be used in compliant chassis. Any modifications made to the equipment may affect the CE compliance standards and should not be done unless approved in writing by Industrial Computer Source.

The Model RS422AT-P is designed to be CE Compliant when used in an CE compliant chassis. Maintaining CE Compliance also requires proper cabling and termination techniques. The user is advised to follow proper cabling techniques from sensor to interface to ensure a complete CE Compliant system. Industrial Computer Source does not offer engineering services for designing cabling or termination systems. Although Industrial Computer Source offers accessory cables and termination panels, it is the user's responsibility to ensure they are installed with proper shielding to maintain CE Compliance.

Chapter 3: Option Selection

Refer to the OPTION SELECTION MAP on page 3-3 when reading this section of the manual. Card operation is determined by jumper installation as described in the following paragraphs.

CTS: *Serial communications will not operate without this signal.* The function of the CTS jumper is to provide the signal when it is not externally supplied. If you prefer, you can omit this jumper and install a jumper between CTS (pin 5) and +5 VDC (pin 9) on the mating D connector P1. This jumper in the mating connector provides a handy diagnostic tool because the card will not operate unless the mating connector is properly installed.

SLOT 8: In order to use the RS422AT-P Serial Interface card in a short slot, install a jumper at this position.

TERMINATIONS AND BIAS: A transmission line should be terminated at the receiving end in its characteristic impedance. Installing a jumper at the location labeled LD applies a 136-ohm load across the input for RS422 mode and across the transmit/receive input/output for RS485 operation. When noise is a potential problem on long lines, the terminating resistor should be divided and its center point grounded to help reduce noise voltage pickup. To accomplish this, also install a jumper at the position marked LD GND for 68-ohm termination resistance on the positive and negative branches of the receiving line.

In RS485 operations, where there are multiple terminals, only the RS485 ports at each end of the network should have terminating resistors as described above. If the card is to have an ungrounded load, do as above except do not install the LDGND jumper. (See Appendix A, Application Considerations.) Also, for RS485 operation, there must be a bias on the RX+ and RX- lines. If the RS422AT-P card is to provide that bias, install jumpers at the locations labeled +BIAS and -BIAS.

RTS CONTROL: For RS485 operation, installing a jumper at the location labeled RTS allows the state of the RTS line to be controlled by the UART. Without this jumper, the RTS signal will always be high and allow the port to start a transmission at any time.

SIMPLEX or DUPLEX: The receiver can be set in either SIMPLEX or DUPLEX by installing jumpers marked SX or DX. Simplex mode is intended for one-way communication; either transmit or receive. Duplex mode allows transmission or reception either simultaneous or alternatively. In DUPLEX mode the receiver is always enabled and the echo of the port's transmission is fed back to the UART receiver. In SIMPLEX mode the receiver is always enabled.

Connections for Simplex (transmit only or receive only) are:

Receive: SX and FDX jumpers, connector pins 12 and 13

Transmit: No jumpers, connector pins 24 and 25

FULL or HALF DUPLEX: Either FULL or HALF DUPLEX can be selected by installing jumpers at the locations labeled FDX or HDX respectively. Full Duplex allows simultaneous bidirectional communications and is selected by installing the FDX jumper. Half Duplex allows bidirectional transmitter and receiver operation but only one at a time. Proper selection depends on the wire connections used to connect the two serial ports.

RS422 operation requires a jumper at FDX and RS485 operation requires a jumper at HDX.

Connections for Half Duplex (transmit and receive taking turns) and Full Duplex (transmit and receive at same time) are as follows:

Half Duplex, 2-wire, w/echo: DX, HDX, and RTS jumpers, connector pins 12 and 13.

Half Duplex, 2-wire, no echo: SX, HDX, and RTS jumpers, connector pins 12 and 13.

Half Duplex, 2-wire, w/echo: DX, FDX, RTS jumpers, T_x on connector pins 12 and 24, R_x on connector pins 13 and 25.

Full Duplex, 4-wire, no echo: DX and FDX, T_x on connector pins 24 and 25, R_x on connector pins 12 and 13.

INTERRUPTS: Interrupt levels IRQ2 through IRQ7 are available. Select the desired level by installing a jumper in one of the locations marked IN2 through IN7.

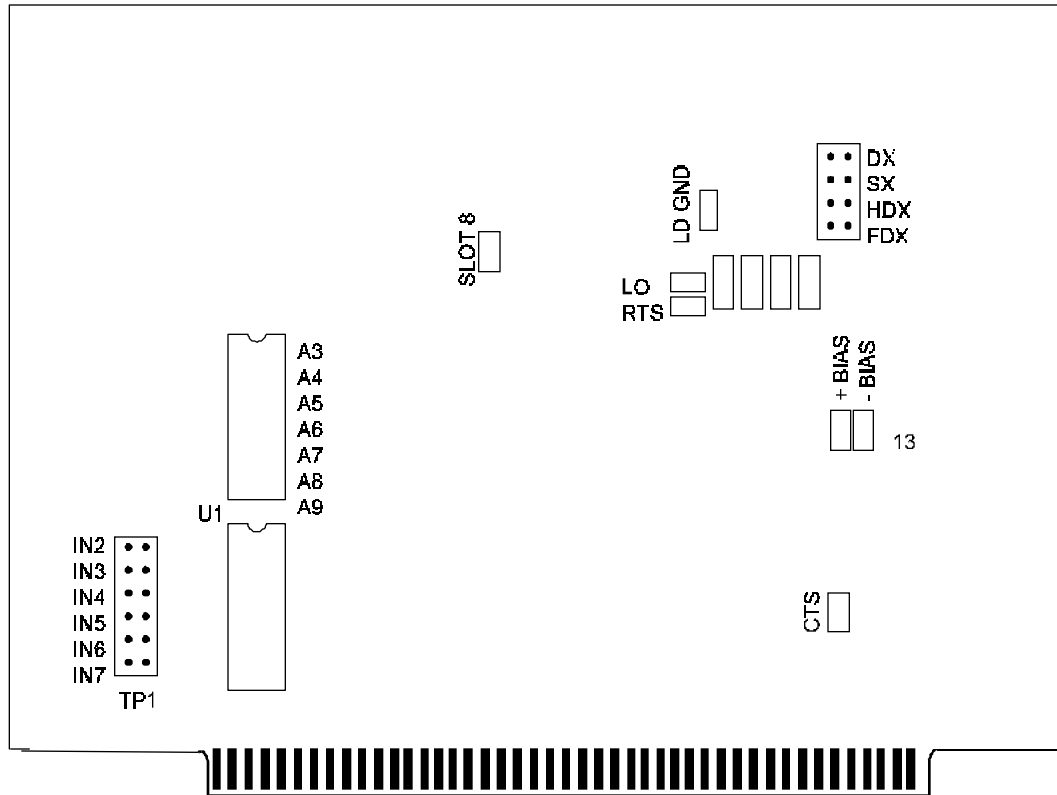

Figure 2: RS422AT-P Option Selection Map

This page intentionally left blank

Chapter 4: Address Selection

The RS422AT-P Serial Interface card base address can be selected anywhere within an I/O address range 100-3FF hex in AT's (except 1F0 through 1F8) and 200-3FF in XT's, providing that the address does not overlap with other functions. If in doubt, refer to the tables below for a list of standard address assignments. (Note: The primary and secondary binary synchronous communication ports are supported by the Operating System.) The base address locator program FINDBASE provided on diskette will assist you to select a base address that will avoid any problem.

| Hex Range | Usage |
|-----------|------------------------------------|
| 000-0FF | Internal System - Not Usable |
| 1F0-1FF | AT Hard Disk |
| 200-207 | Game Control |
| 278-27F | Parallel Port (LPT2) |
| 238-23B | Bus Mouse |
| 2E8-2EF | Asynchronous Communications (COM4) |
| 2F8-2FF | Asynchronous Communications (COM2) |
| 300-31F | Prototype Card |
| 320-32F | XT Hard Disk |
| 378-37F | Parallel Port (LPT1) |
| 380-38F | SDLC Communications |
| 3A0-3AF | SDLC Communications |
| 3B0-3BB | MDA |
| 3BC-3BF | Alt. Parallel Port |
| 3C0-3CF | EGA |
| 3D0-3DF | CGA |
| 3E8-3EF | Asynchronous Communications (COM3) |
| 3F0-3F7 | Floppy Disk |
| 3F8-3FF | Asynchronous Communications (COM1) |

STANDARD ADDRESS ASSIGNMENTS FOR PC AND PC/XT COMPUTERS.

ADDRESS SETUP switches are marked A3-A9. In order to configure the desired address, assign “0” to all ADDRESS SETUP switches turned OFF and assign “1” to all ADDRESS SETUP switches turned ON. These 1’s and 0’s are a binary representation of the base address. This binary number is then converted to a hexadecimal number.

| | | | | | | | |
|-------------------------|----|----|----|----|----|----|----|
| Switch Label | A9 | A8 | A7 | A6 | A5 | A4 | A3 |
| Address Line Controlled | A9 | A8 | A7 | A6 | A5 | A4 | A3 |

For example, as illustrated in the following table, switch selection corresponds to binary 10 1101 1xxx (or hex 2D8). The “xxx” represents address lines A2, A1, and A0 used on the card to select individual registers. See PROGRAMMING section of this manual.

| | | | | | | | |
|-----------------------|----|-----|----|----|-----|----|----|
| Switch Label | A9 | A8 | A7 | A6 | A5 | A4 | A3 |
| Setup | ON | OFF | ON | ON | OFF | ON | ON |
| Binary Representation | 1 | 0 | 1 | 1 | 0 | 1 | 1 |
| Conversion Factors | 2 | 1 | 8 | 4 | 2 | 1 | 8 |
| Hex Representation | 2 | | D | | | | 8 |

Review the Address Selection Table carefully before selecting the card address. If the addresses of two installed functions overlap you will experience unpredictable computer behavior.

Chapter 5: Programming

Sample Programs

There are two sample programs provided on diskette with the RS422AT-P card. These are:

Sample 1

This program is provided in C, Pascal, and QuickBASIC. It performs a test of the loopback feature of the 16450 UART. It requires no external hardware and no interrupts.

Sample 2

This program is provided in C only and demonstrates interrupt-driven RS485 operation. The program requires multiple cards in multiple computers. To operate this program requires a minimum of two computers and a two-wire cable interconnecting them. That cable must connect the Tx+ and Tx-pins from terminal 1 to the Rx+ and Rx-pins respectively at terminal 2 and the Tx+ and Tx-pins from terminal 2 to the Rx+ and Rx-pins at terminal 1.

RS422 PROGRAMMING

Programming for RS422 use is a simplified version of RS485 communications without the overhead of multiple devices on the same line. RS422 also supports multiple devices but only if one port is limited to transmitting and all the other ports are only receivers.

RS485 PROGRAMMING

Programming the 16450 UART for RS485 communications can be divided into three distinct sections: initialization, reception, and transmission. Initialization deals with option setup on the chip including baud rate selection. Reception deals with incoming-character processing which can be done using either polling or interrupts. Transmission deals with the process of sending data out.

Initialization

Initializing the chip requires knowledge of the UART's register set. The first step is to set the baud rate divisor. You do this by first setting the DLAB (Divisor Latch Access Bit) high. This bit is located at Base Address +3, Bit 7. In C, the call would look like:

```
outportb(BASEADDR +3, 0x80);
```

You then load the divisor into Base Address +0 (lower byte) and Base Address +1 (higher byte). The following equation defines the relationship between baud rate and divisor:

$$\text{desired baud rate} = (\text{crystal frequency}) / (16 * \text{divisor})$$

On the COM422/485 card, the crystal frequency is 1.8432 MHz. Commonly used divisors are: 12 for 9600 baud, 48 for 2400 baud, and 96 for 1200 baud. In C, the code to set the chip to 9600 baud is:

```
outportb(BASEADDR, 0x0C);
outportb(BASEADDR +1, 0);
```

The second step in initializing the UART is to set the Line Control Register at Base Address +3. This register defines word length, stop bits, parity, and the DLAB.

Bits 0 and 1 control word length and allow word lengths from 5 to 8 bits. Bit settings are extracted by subtracting 5 from the desired word length.

Bit 2 determines the number of stop bits. There can be either one or two stop bits. If Bit 2 is set to 0, there will be one stop bit. If Bit 2 is set to 1, there will be two stop bits.

Bits 3 through 6 control parity and break enable. They are not commonly used for communications and should be set to 0's.

Bit 7 is the DLAB. It must be set to 0 after the divisor is loaded or else there will be no communications.

The C command to set the UART for an 8-bit word, no parity, and one stop bit is:

```
outportb(BASEADDR +3, 0x03)
```

The third step of the initialization sequence is to set the MODEM control register at Base Address +4. This register controls functions on some cards. Bit 1 is the Request to Send (RTS) control bit. This bit should be left low until transmission time. Bits 2 and 3 are user-designated outputs. Bit 2 may be ignored on this card. Bit 3 is used to enable interrupts and should be set high if an interrupt-driven receiver is to be used.

The final initialization step is to flush the receiver buffers. You do this with two Reads from the receiver buffer at Base Address +0. When this is done, the UART is ready to use.

Reception

Reception can be handled in two ways: polling and interrupt-driven. When polling, reception is accomplished by constantly reading the Line Status Register at Base Address +5. Bit 0 of this register is set high whenever data are available to be read from the chip. A simple polling loop must continuously check this bit and read in data when it becomes available. Polling is not effective at very high data rates because the program cannot do anything else when it is polling or data could be missed. The following is a code fragment that implements a polling loop and uses a value of zero as an end-of-transmission marker:

```
do
{
    while (!(inportb(BASEADDR +5) & 1));    /*Wait until data ready*/
    data[i++] = inportb(BASEADDR);
}
while (data[i] != 0);    /*Reads the line until null character
rec'd*/
```

Interrupt-driven communications should be used whenever possible and is required for data speeds. Writing an interrupt-driven receiver is not much more complex than writing a polled receiver. However, care should be taken when installing or removing your interrupt handler because there is a danger of writing the wrong interrupt, or disabling the wrong interrupt, or even turning interrupts off for too long a period.

The handler would first read the Interrupt Identification Register at Base Address +2. If the interrupt is for Received Data Available, the handler then reads the data. If no interrupt is pending, control exits the routine. As sample handler, written in C, is as follows:

```
do
{
    readback = inportb(BASEADDR +2);
    if(readback & 4) /    /*Readback will be set to 4 if data are
available*/
    data[i++] = inportb(BASEADDR);
}
while(readback != 1);
outportb(0x20, 0x20);    /*Write EOI to 8259 Interrupt Controller*/
return;
```

The preceding examples accept only a single character input. The code would need to be modified to handle larger data structures.

Transmission

RS485 transmission is simple to implement. First, the RTS line should be set high by writing a 1 to Bit 1 of the MODEM control register at Base Address +4. The RTS line is used to toggle the transceiver from receive mode to transmit mode and vice versa. It is not carried out on the line in RS485 and not used for handshaking.

Similarly, the CTS line is not used in RS485 and should always be enabled by installing a jumper as described in the Option Selection section of this manual.

After the above are done, the card is ready to send data. To transmit a string of data, the transmitter must first check Bit 5 of the Line Status Register at Base Address +5. That bit is the transmitter-holding-register-empty flag. If it is high, the transmitter has sent the data. The process of checking the bit until it goes high followed by a write is repeated until no data remains. After all data has been transmitted, the RTS bit should be reset by writing a 0 to Bit 1 of the MODEM control register .

The following C code fragment demonstrates this process:

```

outportb(BASEADDR +4, inportb(BASEADDR +4)|0x02); /*Set RTS bit
without altering states of other bits*/
while(*data) /*While there is data to send*/
{
    while(!(inportb(BASEADDR +5)&0x20));/*Wait until transmitter
is empty*/
    outportb(BASEADDR,*data);
    data++;
}
outportb(BASEADDR +4, inportb(BASEADDR +4)&0xFD;
/*Reset RTS bit without altering states of other bits*/

```

Chapter 6: Connector Pin Assignments

The popular 25-pin D subminiature connector is used for interfacing to communication lines. The connector is equipped with 4-40 threaded standoffs (female screw lock) to provide strain relief. The mating connector is AMP type 747304-2 or equivalent. We recommend using vinyl-jacketed, multiple twisted-pair cable. Connector pin assignments are as follows:

| Pin # | Assignment |
|-------|-----------------------|
| 1 | |
| 2 | |
| 3 | |
| 4 | Request to Send (RTS) |
| 5 | Clear to Send (CTS) |
| 6 | |
| 7 | Signal Ground (GND) |
| 8 | |
| 9 | |
| 10 | |
| 11 | |
| 12 | Receive Line + (RX+) |
| 13 | Receive Line - (RX-) |
| 14 | |
| 15 | |
| 16 | |
| 17 | |
| 18 | |
| 19 | |
| 20 | |
| 21 | |
| 22 | |
| 23 | |
| 24 | Transmit Line + (TX+) |
| 25 | Transmit Line - (TX-) |

NOTE: For Simplex, Half Duplex, and Full Duplex operation, see The Option Selection section of this manual for pin connection information.

This page intentionally left blank

Chapter 7: Specifications

| | |
|------------------------------|---|
| Multipoint: | Compatible with RS422 and RS485 specifications. Up to 32 drivers and receivers allowed on line. Serial communications ACE used is type NS16450. Transceivers used are type 75176. |
| Input Common Mode Voltage: | -7V to +12V. |
| Receiver Input Sensitivity: | +/-200mV, differential input. Thermal shutdown protection. |
| Output Drive Capability: | +/-60 mA max., differential. Thermal shutdown protection. |
| Tranzorbs: | Optional Tranzorbs can be added to I/O lines for additional protection (Option T). |
| RTS and CTS: | Lines available on output connector. |
| Auxiliary Power Output: | +5VDC at 20mA at connector pin 9. |
| Baud Rate: | 50 to 56000 baud. Crystal oscillator provided. |
| Address: | Eight bytes, continuously mappable within I/O address range 000 to 3FF hex. |
| Environmental: | |
| Operating Temperature Range: | 0 to +60 degr.C |
| Storage Temperature Range: | -50 to +120 degr.C |
| Humidity: | 5% to 95%, non-condensing. |
| Power Required: | +5VDC at 400 mA typical. |
| Size: | 4.9" long. Can mount in half-or full-size slot. |

This page intentionally left blank

Appendix A: Application Considerations

Working with RS-422 and RS-485 devices is not much different from working with a standard RS-232 serial adaptor. RS-232 devices have two major deficiencies for industrial applications.

First, the cable length between RS-232 devices must be short; less than 50 feet at 9600 baud.

Second, many RS-232 errors are the result of noise induced on the cables. The RS-422 standard permits cable lengths up to 5000 feet and, because it operates in the differential mode, it is highly immune to induced noise.

Connections between two RS-422 devices (with CTS ignored) should be as follows:

| Device #1 | | Device #2 | |
|-----------|-------|-----------|-------|
| Signal | Pin # | Signal | Pin # |
| GND | 7 | GND | 7 |
| TX+ | 24 | RX+ | 12 |
| TX- | 25 | RX- | 13 |
| RX+ | 12 | TX+ | 24 |
| RX- | 13 | TX- | 25 |

NOTE

If you are connecting the RS422AT-P to another manufacturer's device, you should make sure that the line is properly terminated by the other device. Also, other RS-422 devices may not use the same 25-pin connectors and pins. Consult the technical manual for that other device.

A third deficiency of RS-232 is that more than two devices cannot share the same cable. This is also true for RS-422 but RS-485 offers all the benefits of RS-422 plus also allows up to 32 units to share the same twisted pairs.

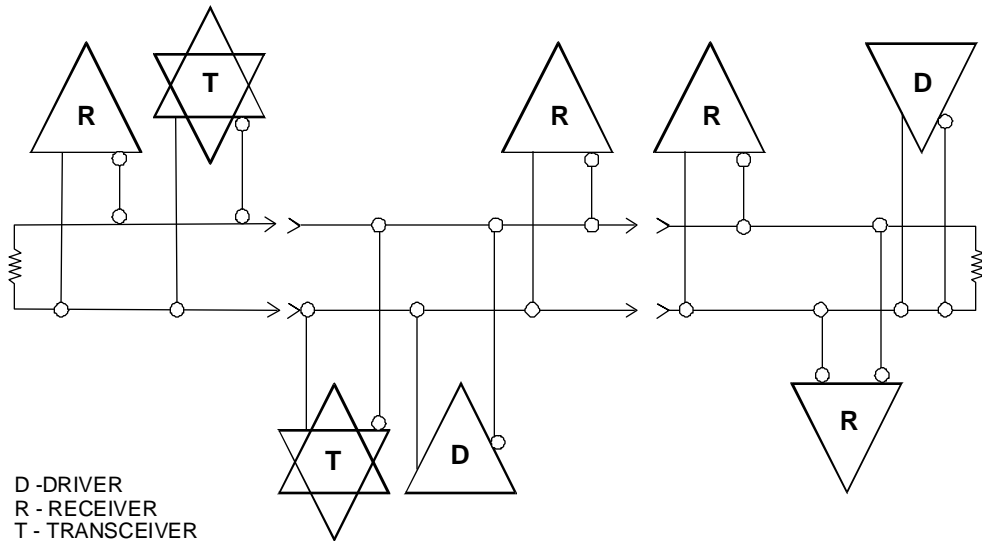

In both the RS-422 and the RS-485 mode, the receiver end of the cable between the stations must be terminated with a resistor equal to the characteristic impedance of the wire. This is to prevent signal reflections in the wire and to improve noise rejection. However, you do not have to add a terminator resistor to your cables when you use the RS422AT-P card. Termination resistors for the RX+ and RX- lines are provided on the card and are placed in the circuit when you install the LD and LDGND jumpers. Moreover, installing the +BIAS and -BIAS jumpers properly biases these lines. (See Option Selection chapter of this manual.)

Declaration of Conformity



6260 Sequence Drive
San Diego, CA 92121-4371
(800) 523-2320

Industrial Computer Source declares under its own and full responsibility that the following products are compliant with the protection requirements of the 89/336/EEC and 73/23/EEC directives.

Only specific models listed on this declaration and labeled with the CE logo are CE compliant.

RS422AT-P

Conformity is accomplished by meeting the requirements of the following European harmonized standards:

EN 50081-1:1992 Emissions, Generic Requirements.

-EN 55022 Measurement of radio interference characteristics of information technology equipment.

EN 50082-1:1992 Immunity, Generic Requirements.

-IEC 801-2:1984 Immunity for AC lines, transients, common, and differential mode.

-IEC 801-3:1984 Immunity for radiated electromagnetic fields.

-IEC 801-4:1988 Immunity for AC and I/O lines, fast transient common mode.

EN 60950:1992 Safety of Information Technology Equipment.

Information supporting this declaration is contained in the applicable Technical Construction file available from:



Z.A. de Courtaboeuf
16, Avenue du Québec
B.P. 712
91961 LES ULIS Cedex

Mr. Steven R. Peltier
President & Chief Executive Officer

September 10, 1997
San Diego, CA

BUG REPORT

While we have tried to assure this manual is error free, it is a fact of life that works of man have errors. We request you to detail any errors you find on this BUG REPORT and return it to us. We will correct the errors/problems and send you a new manual as soon as available. Please return to:



INDUSTRIAL COMPUTER SOURCE®

Attn: Documentation Department
P. O. Box 910557
San Diego, CA 92121-0557

Your Name: _____

Company Name: _____

Address 1: _____

Address 2: _____

Mail Stop: _____

City: _____ State: _____ Zip: _____

Phone: (____) _____

Product: **RS422AT-P**

Manual Revision: **00650-008-35B**

Please list the page numbers and errors found. Thank you!

